



**CỤC ĐĂNG KIỆM VIỆT NAM**  
**VIETNAM REGISTER**

ĐỊA CHỈ: 18 PHẠM HÙNG, HÀ NỘI  
ADDRESS: 18 PHAM HUNG ROAD, HA NOI  
ĐIỆN THOẠI/ TEL: +84 4 3 7684701  
FAX: +84 4 3 7684779  
EMAIL: vr-id@vr.org.vn  
WEB SITE: www.vr.org.vn

**THÔNG BÁO KỸ THUẬT TÀU BIỂN**  
**TECHNICAL INFORMATION ON SEA-GOING SHIPS**

**Ngày 07 tháng 9 năm 2015**

**Số thông báo: 022TI/15TB**

*Nội dung: Thông tư MSC.1/Circ.1513 - Sửa đổi bổ sung đối với Sổ tay tìm kiếm và cứu nạn hàng không, hàng hải quốc tế (IAMSAR).*

Kính gửi: Các chủ tàu/ công ty quản tàu biển  
Các đơn vị đăng kiểm tàu biển

Ngày 28 tháng 7 năm 2015, Tổ chức Hàng hải quốc tế (IMO) đã ban hành Thông tư MSC.1/Circ.1513 về sửa đổi bổ sung đối với Sổ tay tìm kiếm và cứu nạn hàng không, hàng hải quốc tế (IAMSAR). Sửa đổi, bổ sung này sẽ có hiệu lực từ ngày 01 tháng 7 năm 2016.

Theo quy định V/21 của Công ước quốc tế về an toàn sinh mạng con người trên biển (SOLAS), tất cả các tàu biển đều phải có tập III của Sổ tay tìm kiếm và cứu nạn hàng không, hàng hải quốc tế (IAMSAR).

Chúng tôi xin gửi kèm theo Thông báo kỹ thuật tàu biển này Thông tư MSC.1/Circ.1513 và đề nghị các Quý Đơn vị lưu ý áp dụng theo đúng quy định.

Thông báo kỹ thuật này được nêu trong mục: *Thông báo của VR/ Thông báo kỹ thuật TB* của trang tin điện tử của Cục Đăng kiểm Việt Nam: <http://www.vr.org.vn>.

Nếu Quý Đơn vị cần thêm thông tin về vấn đề nêu trên, đề nghị vui lòng liên hệ:

*Cục Đăng kiểm Việt Nam*

*Phòng Tàu biển*

*Địa chỉ: 18 Phạm Hùng, Phường Mỹ Đình 2, Quận Nam Từ Liêm, Hà Nội*

*Điện thoại: +84 4 37684701 (số máy lẻ: 521)*

*Fax: +84 4 37684722*

*Thư điện tử: [taubien@vr.org.vn](mailto:taubien@vr.org.vn); [bangph@vr.org.vn](mailto:bangph@vr.org.vn)*

Xin gửi đến các Quý Đơn vị lời chào trân trọng./.

**Nơi nhận:**

- Như trên;
- Phòng QP, TB, CN, HTQT;
- Trung tâm VRQC, TH;
- Các chi cục đăng kiểm;
- Lưu TB./.

---

4 ALBERT EMBANKMENT  
LONDON SE1 7SR  
Telephone: +44 (0)20 7735 7611 Fax: +44 (0)20 7587 3210

MSC.1/Circ.1513  
28 July 2015

**AMENDMENTS TO THE INTERNATIONAL AERONAUTICAL  
AND MARITIME SEARCH AND RESCUE (IAMSAR) MANUAL**

- 1 The Maritime Safety Committee (MSC), at its ninety-fifth session (3 to 12 June 2015), having been informed that the International Civil Aviation Organization (ICAO) had approved the amendments to the IAMSAR Manual prepared by the ICAO/IMO Joint Working Group on Harmonization of Aeronautical and Maritime Search and Rescue, and that they had been endorsed by the Sub-Committee on Navigation, Communications and Search and Rescue (NCSR) at its second session, approved the annexed amendments in accordance with the procedure laid down in resolution A.894(21).
- 2 This circular revokes COMSAR/Circ.23 and COMSAR.1/Circ.57.
- 3 The Committee decided that the amendments should become applicable on 1 July 2016.

\*\*\*

## ANNEX

### PROPOSED AMENDMENTS TO IAMSAR MANUAL VOLUME I

#### 1 Contents

- Add on page iii the following text:

#### 4.9 Social Media

On page iv, chapter 6, renumber existing sections 6.7 and 6.8 to 6.8 and 6.9

On page iv, chapter 6, insert new section 6.7 Multiple aircraft SAR operations

On page iv, amend the text related to appendix J as follows:

~~Sample terms of reference for a SAR coordinating committee agreement~~

#### 2 Abbreviations and Acronyms

- Delete the following text on page vii:

~~AES.....aeronautical earth station~~

~~CES.....coast earth station~~

~~GES.....ground earth station~~

#### 3 Glossary

- Delete the following text on page xi:

~~Coast earth station (CES) Maritime name for an Inmarsat shore-based station linking ship earth stations with terrestrial communications networks.~~

- Amend the Glossary as follows:

**Cospas-Sarsat System** A satellite system designed to detect and locate activated distress beacons transmitting ~~on~~ in the frequency band of 406.0-406.1 MHz.

**Direction Finding (DF)** ~~Homing on signals to pinpoint a position.~~  
Radiodetermination using the reception of radio waves for the purpose of determining the direction of a station or object.

**Emergency Locator Transmitter(ELT)**

~~Aeronautical distress beacon for alerting and transmitting homing signals.~~ A generic term (related to aircraft) describing equipment which broadcast distinctive signals on designated frequencies and, depending on application, may be automatically activated by impact or be manually activated.

**NAVAREA**

~~One of 16 areas into which the world's oceans are divided by the International Maritime Organization for dissemination of navigation and meteorological~~

warnings. A geographical sea area established for the purpose of coordinating the broadcast of navigational warnings. The term NAVAREA followed by a roman numeral may be used to identify a particular sea area. The delimitation of such areas is not related to and shall not prejudice the delimitation of any boundaries between States.

**Personal locator beacon (PLB)**

~~Personal radio distress beacon for alerting and transmitting homing signals.~~ A portable device, manually activated, which transmits a distress signal on 406 MHz, and may have an additional homing signal on a separate frequency.

**Search and rescue point of contact (SPOC)**

~~Rescue co-ordination centres and other established and recognized national points of contact which can accept responsibility to receive Cospas-Sarsat alert data to enable the rescue of persons in distress. A point of contact for SAR, designated by the national administration, that is responsible for receiving distress alert information and providing the information to appropriate SAR authorities.~~

**Rescue co-ordination centre (RCC)**

Note: The term RCC will be used within this Manual to apply to either aeronautical, maritime or joint centres; ARCC, MRCC or JRCC will be used as the context warrants.

- Add the following:

**Area of SAR action** An area of defined dimensions that is established, notified or agreed for the purposes of protecting aircraft during SAR operations and within which SAR operations take place.

#### 4 Chapter 2

- Amend page 2-7, paragraph 2.3.11(c), 9<sup>th</sup> line as follows:

... is responsible for planning the search and rescue operations and coordinating the transit of SRUs SAR facilities to and from the scene."

- Amend page 2-11, paragraph 2.6.1, 7<sup>th</sup> line as follows:

...plan the search and/or rescue if the OSC becomes aware of a distress situation directly..."

- Amend page 2-11, paragraphs 2.6.2 to 2.6.4 as follows:

2.6.2 Responsible authorities should find ways for information, of training and exercising the OSC and ACO functions, both for those who act as ACOs in these roles and for those who co-operate closely with them ACOs.

### **On Scene Coordinator (OSC) and Aircraft Coordinator (ACO) joint training**

2.6.3 The SAR management should provide OSC and ACO training between SRU crews from different organizations that might act as OSCs or ACOs. The ACO training should improve understanding of the OSC and ACO roles and increase confidence amongst the participating SRUs.

2.6.4 OSC and ACO training can consist of:

- lessons from real life SAR missions;
  - legal documents;
  - duties of co-operating organizations;
  - performance characteristics of SRUs;
  - typical cases and methods;
  - SMC-OSC-ACO role-playing; and
  - paper exercises."
- Insert new subsection at the end of section 2.5 **SAR Facilities** called **Area of SAR action** as follows:

#### **Area of SAR action**

2.5.7 During SAR operations the SAR aircraft involved should be able to carry out their activities without interference from other air activity. Additionally, aeronautical organizations and aircraft not involved in a SAR operation, need to be made aware of it for their safety. The temporary establishment of appropriate areas surrounding SAR operations might improve safety and inform others of SAR activity.

2.5.8 An "Area of SAR Action" is an area of defined dimensions used or agreed by appropriate authorities for the protection of aircraft during SAR operations. It should be assumed that within areas of SAR action special flying procedures relevant to SAR operations might take place. Areas of SAR action are described in further detail in Volume II Chapter 7.

2.5.9 SAR organizations should arrange that RCC have methods in place for implementing areas of SAR action to facilitate SAR operations.

- Insert new subsection at the end of section 2.7 **Support Facilities** called **SAR Refuelling Facilities** as follows:

#### **SAR Refuelling Facilities**

2.7.6 In parts of a SRR without refuelling facilities, SAR organizations should arrange that RCC have alternative plans for refueling SRUs in place.

2.7.7 Existing facilities, such as airfields, land-based refuelling facilities close to coastlines, offshore drilling platforms and vessels that can refuel aircraft, could also be used. Where possible, it is recommended for SAR management to make preparatory agreements with operators of such facilities for use in SAR operations.

## **5 Chapter 3**

- Amend page 3-2, paragraph 3.2.1, as follows:

3.2.1 All SAR specialists need some training, in particular, the SCs, RCC chiefs, SMCs, RCC staff, and OSCs, ACOs and SRUs.

- Amend page 3-3, paragraph 3.2.11, as follows:

Add "Mass rescue operations" to the list of general categories.

## 6 Chapter 4

- Amend page 4-5, paragraph 4.4.8, last sentence as follows:

If there is any way to confirm the position reported in an alert, it would be prudent to do so, especially with initial EPIRB and ELT 406 MHz distress beacon alerts via Cospas-Sarsat which may provide an "A" position and a "B" position that indicates either one could be the both a true position and the other is an image position

- Amend page 4-6, paragraph 4.5.2, third bullet point as follows:

- Inmarsat land earth stations (LEEs) (also known as maritime coast earth stations (CESs) and aeronautical ground earth stations (AGESs));

- Amend page 4-7, paragraph 4.5.11, first line as follows:

- ARCCs and MRCCs may install and use Inmarsat CESs LEEs or ship earth...

- Amend page 4-9, paragraph 4.5.26, first bullet point as follows:

- Arrange for CRSs and CESs LEEs to relay ship messages...

Add in new section at end of page 4-10 as follows:

### 4.9 Social media

4.9.1 Social media are not part of the international distress alerting system and is not monitored as a primary means of distress notification. However, the public uses social media to create online communities to share information, ideas, personal messages and other content. This can raise a public expectation that SAR authorities, especially for prolonged SAR incidences with news media interest, should either provide information to or accept information from social media sites. RCCs should have procedures in place for efficient management of social media.

## 7 Chapter 5

- Amend page 5-4, paragraph 5.2.14, last sentence as follows:

Appendix I contains ~~sample text and guidance for a national SAR plan~~ guidance and a sample SAR agreement.

- Amend page 5-9, add a new paragraph after paragraph 5.4.4 as follows:

5.4.5 In some circumstances there may be a need for immediate response to large numbers of persons in distress such that the capabilities normally available to the SAR authorities are inadequate. These are known as mass rescue operations: see chapter 6. SAR managers should plan for such operations by

- agreeing to share SAR facilities regionally and/or internationally;
  - identifying additional SAR facilities locally, including shipping in the area; and
  - identifying ways of providing support to persons in distress until they can be rescued.
- Renumber existing paragraphs 5.4.5 through 5.4.16 to 5.4.6 through 5.4.17
  - Amend page 5-10, table 5-2, middle column, "Coordinate SAR services" row, 4th item as follows:

Plan searches search and rescue operations

- Amend page 6-4, paragraph 6.4.5, fourth line as follows:

Appendix J contains ~~a sample text and guidance for an SCC~~ agreement.

- Amend page 6-7, paragraph 6.5.5 first bullet point, third line as follows:

...(which are now more and more being fitted with AESs linked to satellite communication (satcom) equipment linked to LESSs)...

- Renumber existing sections 6.7 and 6.8 to 6.8 and 6.9
- Add in new section on **Multiple SAR Operations** as follows:

### 6.7 Multiple aircraft SAR operations

6.7.1 A multiple aircraft SAR operation is one in which two or more aircraft are taking part.

#### **Safety**

6.7.2 SAR organizations should establish plans and procedures to ensure that multiple aircraft SAR operations can be performed efficiently while flight safety is maintained.

#### **Notes:**

1. *Depending on the State's aviation regulatory framework, SAR organizations may need to work in conjunction and collaboration with the relevant State civil aviation*

*regulatory, air navigation service providers and military aviation authorities to establish such plans and procedures.*

2. *Plans and procedures need to take into account possible operational and procedural differences that may exist between civil and military operations.*

### **Common Procedures**

6.7.3 Differences in the availability of airborne SRUs, capabilities and geography across different SRRs, cause regional differences in plans for multiple aircraft SAR operations. Significant differences may increase risks to safety during operations in which aircraft, SRUs or staff from different SAR organizations works together.

6.7.4 In order to promote safety, effectiveness and best practise, it is important that SAR organizations develop plans for multiple aircraft SAR operations based on common procedures and principles. Relevant procedures and principles are described in the IAMSAR Volume II Chapter 7 and Volume III Section 5.

6.7.5 It is recommended that SAR organizations share their experiences and recommendations for multiple aircraft SAR operations with each other, and their State civil and military aviation authorities, to improve procedures and plans.

## **8 Appendix E**

- Amend text on page E-3 as follows:
  - once an EPIRB is switched on, ~~whether accidentally or intentionally~~, the vessel should make every reasonable attempt to communicate with SAR authorities by other means to advise them of the situation ~~before turning the EPIRB off~~;
  - if an EPIRB is accidently activated, it should be turned OFF as soon as practicable and the RCC should be notified that the alert is false. In cases where the beacon cannot be turned OFF, measures should be taken to prevent or inhibit the transmission of signal. Such actions may render the beacon inoperable for future use unless it is serviced by an appropriate service facility;
  - after emergency use, if possible, retrieve and deactivate the EPIRB.

## **9 Appendix I**

- Amend text of second to last paragraph as follows:

The concept of "territory" is understood to include territorial land, territorial sea and the airspace above them ~~and seas~~.

- Insert new text at the bottom of page 1, as follows:

IMO and ICAO use the term "agreement" but many States view this as type of a legal instrument. Different terms may be used for the title of a legal instrument, such as "Agreement", "Memorandum of Understanding", "Arrangement" and other related terms. The type of instrument can be decided by the States involved as long as the document meets the intent of the international conventions to serve as the basis for cooperation and the provision of expeditious and effective SAR services.



In some cases, the term "Search and Rescue Point of Contact (SPOC)" can be used in lieu of Rescue Coordination Centre (RCC). The definition of SPOC includes the RCC and some national SAR authorities that may not have an internationally designated RCC.

This template serves as guidance for States to draft a SAR Agreement (which may take the form of an MOU or Arrangement or other) and the text to be included in this document is for the Parties to decide.

- Replace the current appendix I "SAR Agreement" as follows:

### **Bilateral or Regional SAR Agreement**

#### **Agreement FOR COOPERATION BETWEEN THE [name of national agency/State] AND [name of national agency/State]**

**Note:** *The term agreement is used in order to be consistent with ICAO Annex 12 and the International Convention on Maritime Search and Rescue. State may elect to use a different term such as "Memorandum of Understanding", "Letter of understanding", "Arrangement" or others as appropriate.*

*This template serves as guidance for States to draft a SAR Agreement (which may take the form of an MOU or SAR Arrangement or other instrument title) and the text to be included in this document is for the Parties involved to decide.*

### **CONCERNING AERONAUTICAL [AND/OR] MARITIME SEARCH AND RESCUE**

#### **1. Introduction**

**1.1** The [name of national agency/State] and [name of national agency/State] (hereinafter referred to as the "Parties" in this Agreement, recognize the benefits enjoyed from previous close cooperation with regard to search and rescue SAR operations and training, and further recognize that additional benefits may be enjoyed from the cooperative arrangements detailed herein; and

**1.2** The Parties have been recognized by their respective governments as having primary responsibility for coordinating and providing aeronautical and maritime SAR services in their respective aeronautical and maritime SAR regions.

**1.3** The Parties recognize the great importance of cooperation in aeronautical and maritime SAR, and in the provision of expeditious and effective SAR services to save lives and reduce suffering and have assumed their respective responsibilities for SAR within the framework of the International Convention on Maritime Search and Rescue, 1979, the Convention on International Civil Aviation, 1944, and the International Aeronautical and Maritime Search and Rescue (IAMSAR) Manual.

**1.4** The Parties have accordingly reached the following understanding.

## **2. Objectives and Scope**

**2.1** This agreement establishes a framework for cooperation among the Parties in carrying out activities related to SAR within the aeronautical and/or maritime environment and sets out their various responsibilities.

**2.2** The Parties should ensure close coordination with their respective national aeronautical and maritime SAR authorities to help promote common and effective SAR services under this agreement.

## **3. Responsibilities**

**3.1** [name of national agency] and [name of national agency] are each responsible for the maintenance of safety of life and within their respective aeronautical and maritime SAR regions, under their respective Rescue Coordination Centre (RCC).

**3.2** Each Party, on receiving information of an incident where any person is in distress within its SAR region, should take urgent measures to provide the most appropriate assistance regardless of the nationality or status of such a person, or the circumstances in which that incident occurred or is detected.

**3.3** SAR operations should normally be carried out in accordance with the relevant SAR manuals and recommendations of International Civil Aviation Organization (ICAO) and the International Maritime Organization IMO, including the IAMSAR Manual (as amended from time to time), taking into account SAR procedures established by national legislation.

**3.4** The Parties should make every effort to retrieve persons in distress, provide for their initial medical or other needs and deliver them to a place of safety; additionally, when it does not involve excessive risk or cost to the units involved in SAR operations, the Parties may attempt to rescue the craft or vessel on which the persons in danger are aboard.

**3.5** To ensure that SAR operations are conducted in an efficient and coordinated manner, the Parties should consult and cooperate with each other as necessary and appropriate, lending mutual assistance as their capabilities allow.

**3.6** Either Party may conduct SAR operations within the SAR region of the other Party under the coordination of that other Party's RCC.

**3.7** Entry of the SAR units of one Party into or over the territory of the other Party for the purpose of conducting SAR operations should be expeditiously arranged to the best of each Party's ability and via the appropriate RCCs.

**3.8** Solely for the purpose of searching for the site of an accident, rescuing survivors of such accidents, rendering emergency rescue assistance to persons, vessels, or aircraft in danger or distress and when the location is reasonably well known, permission to enter its territory shall be granted by a State to another State's search and rescue unit(s), provided that a request has been transmitted to the rescue coordination centre of the concerned State or to such other authority as has been designated by the State.

**3.9** The RCC of the State requesting assistance or the use of suitable SAR facilities of another State ("the requesting RCC" and "the assisting State" respectively), shall provide all pertinent details on the scope of the assistance or facilities required. The requesting RCC should provide a full briefing, directly or indirectly, to the SAR Units that have been made available by the assisting State, on the scope of the mission before the SAR units enter the

SRR of the requesting RCC. If it is necessary for the SAR Units of an assisting State to land at an airfield or to make use of the facilities of the requesting RCC in the course of performing an assigned SAR task, the RCC concerned should make all necessary arrangements to facilitate the taking of such measures or actions.

**3.10** To facilitate the coordination referred to in this section, the Parties should, to the best of their ability, keep each other fully and promptly informed of all relevant SAR operations. The Parties should develop appropriate procedures in accordance with the IAMSAR Manual to provide for the most effective and efficient means of communication.

#### **4. SAR Regions**

**4.1** The aeronautical and maritime SAR regions of [State] and [State] are separated geographically by a continuous line as follows:

[Provide the geographic coordinates of the lines of delimitation between both States' SAR regions only. Add additional States lines of delimitation for regional SAR Agreement.]

**4.2** The establishment of SAR regions is intended only to provide an understanding concerning the regions within which a Party accepts primary responsibility for coordinating SAR operations.

**4.3** The delimitation of SAR regions is not related to and does not prejudice or have any bearing on the delimitation of any boundary between States.

#### **5. Rescue Coordination Centres (RCCs)**

**5.1** The primary operational points of contact under this Agreement are the internationally recognized aeronautical and maritime RCCs of the Parties.

**5.1.1** [Identify national RCC]

**5.1.2** [Identify national RCC]

**5.2** The Parties, to the best of their ability, should provide to each other any information which might be useful in order to expedite and improve coordination.

**5.3** Identification of the operational points of contact, as referred to in this Section, is not intended to preclude appropriate direct coordination between any SAR facility or organizational unit of the Parties, especially when time is of the essence in the saving of lives.

**5.4** Transfer of SAR mission coordination responsibilities between the RCCs, if deemed necessary, should be conducted by consultation between RCCs.

#### **6. Cooperation**

**6.1** The subordinate elements of the Parties may provide for further coordination and cooperation by the establishment of appropriate operational arrangements and procedures consistent with this Agreement.

**6.2** In addition to information related to specific SAR cases, the Parties may exchange any other information that may serve to improve the effectiveness of SAR operations. This information may include, but not be limited to:

**6.2.1** communication details;

**6.2.2** information about SAR facilities;

**6.2.3** descriptions of available airfields;

**6.2.4** knowledge of fuelling and medical facilities; and

**6.2.5** information useful for training SAR personnel.

**6.3** The Parties will endeavour to promote mutual SAR cooperation by giving due consideration to collaboration including, but not limited to:

**6.3.1** exchange visits between SAR personnel;

**6.3.2** joint SAR exercises and training;

**6.3.3** the use of ship reporting systems for SAR purposes;

**6.3.4** sharing of information systems, SAR procedures, techniques, equipment, and facilities;

**6.3.5** provision of services in support of SAR operations;

**6.3.6** coordination of national positions on international SAR issues of mutual interest;

**6.3.7** supporting and conducting joint research and development initiatives aimed at reducing search time, improving rescue effectiveness, and minimizing risk to SAR personnel; and

**6.3.8** conducting regular communications checks and exercises, including the use of alternative means of communications that would be used to handle communication overloads during major SAR operations.

## **7. Finances**

**7.1** Unless otherwise agreed by the Parties, each Party is to fund its own expenses for activities pertinent to this Agreement.

**7.2** The provisions of the Agreement are contingent upon the availability of SAR personnel, facilities and funding.

**7.3** SAR services provided by the Parties to persons in danger or distress are to be without subsequent cost recovery from the person(s) assisted.

## **8. Application of this Agreement**

**8.1** Nothing in this Agreement is intended to affect in any way rights and duties based on international agreements or other arrangements between the Parties or their respective governments.

**8.2** All activities conducted under this Agreement should be in conformity with national legislation of the Parties, as well as with the relevant international conventions in force.

**8.3** No provision of this Agreement should be construed as an obstacle to prompt and effective action by any Party to relieve distress whenever and wherever found.

**8.4** Any dispute regarding the interpretation or implementation of this Agreement is to be resolved by consultation between the Parties and is not to be referred to any international body, court or third party for settlement.

## **9. Modification**

**9.1** This Agreement may be modified in writing by the Parties.

## **10. Duration, Withdrawal and Discontinuation**

**10.1** Cooperation under this Agreement may commence from the date of signature and may continue indefinitely.

**10.2** Either Party may withdraw from this Agreement at any time, upon giving not less than six (6) months' notice in writing to the other Party.

**10.3** Cooperation under this Agreement may be discontinued mutually by the Parties in writing, or by any superseding arrangement.

**10.4** The Parties should ensure that such discontinuation does not adversely impact any SAR operations or other cooperation in progress at the time that such discontinuation takes effect and should consult each other closely for this purpose.

**Signed in duplicate at [City, State], this \_\_\_\_ day of \_\_\_\_\_, 2016.**

**For the [national agency]:**

\_\_\_\_\_  
**Signature of Authorized Signatory**

**Name:** \_\_\_\_\_

**Designation:** \_\_\_\_\_

**Organization:** \_\_\_\_\_

**Signed in duplicate at [City, State], this \_\_\_\_ day of \_\_\_\_\_, 2016.**

**For the [national agency]:**

\_\_\_\_\_  
**Signature of Authorized Signatory**

**Name:** \_\_\_\_\_

**Designation:** \_\_\_\_\_

**Organization:** \_\_\_\_\_

## **10 Appendix J**

- Replace text of appendix J as follows:

**Sample [National] SAR [Co-ordinating] Committee agreement  
[State name]  
National Search and Rescue Committee  
Interagency Agreement**

**1. PURPOSE**

1.1 This Agreement provides for a national-level Committee to coordinate civil search and rescue (SAR) matters of interagency interest within [State name].

**2. BACKGROUND**

2.1 The National Search and Rescue Committee (NSARC) is established as a standing interagency group to oversee the National Search and Rescue Plan (NSP) and to act as a coordinating forum for national SAR matters. [Note: If the National Search and Rescue Plan (NSP) is created first, then the paragraph could read as: The [State] National Search and Rescue Plan (NSP) established a standing interagency group to oversee the NSP and to act as a coordinating forum for national SAR matters. This group is named the National Search and Rescue Committee (NSARC).]

**3. SPONSORSHIP**

3.1 The [name of national agency] is the sponsor of NSARC. The [name of national agency] shall:

3.2 Designate an executive-level person to Chair the Committee, who shall report to the Secretary of [Department or Ministry name] via the [name of national agency]; and

3.3 Appoint a Committee Secretary to ensure that the Committee operates according to policies and procedures contained in current directives.

**4. MEMBERSHIP, OBSERVERS AND ADVISORS**

4.1 The Member Agencies of the Committee are as follows:

.....  
.....  
.....

[e.g.: Ministry/Department of Defence, Ministry/Department of Transportation; Ministry/Department of Commerce, National Police, Emergency Management Agency, Medical, etc.]

4.2 Each of these Member Agencies shall designate one representative by name or position to serve as its primary Committee Member, and another to serve as its Alternate Committee Member.

4.3 Each Committee Member may call upon officials in that agency to serve as Advisors and to participate in meetings of the Committee, or of subsidiary groups of the Committee.

4.4 Others may be invited with the approval of the Chair or the Committee to participate as government or non-government Observers on an ad hoc basis.

**5. NATIONAL SEARCH AND RESCUE PLAN PARTICIPATION**

5.1 Member Agencies of NSARC are, by virtue of their membership, also Participants to the National Search and Rescue Plan of [State name].

## **6. OBJECTIVES**

**6.1** The objectives of the Committee are to:

**6.1.1** Recommend implementation strategies and actions that ensure that the [State] meets domestic needs and international commitments to provide effective civil SAR services;

**6.1.2** Hold sole responsibility for the provisions of the NSP;

**6.1.3** Serve as the primary coordinating forum within the national government for the conduct and support of civil SAR operations covered by the NSP, and for matters relating to national civil SAR policies and positions;

**6.1.4** Administer the National Search and Rescue Supplement to the International Aeronautical and Maritime Search and Rescue Manual for interagency guidance on implementing the NSP;

**6.1.5** Seek to ensure compatibility between the NSP and the National [Disaster] Response Plan (NRP) so that the NSP can be implemented independently or concurrently with the NRP during an incident of national significance;

**6.1.6** Promote application of research and development, improved standards and procedures, new technologies, regulations, and education to improve the effectiveness and efficiency of distress alerting and other civil SAR services, and to reduce the associated risks;

**6.1.7** Help coordinate the civil SAR efforts of the NSARC Member Agencies with other national and international government, private, and volunteer organizations;

**6.1.8** Promote the effective use of all available resources to support civil SAR;

**6.1.9** Foster appropriate use of SAR agreements and other arrangements and plans to improve cooperation and mutual support among the various national and international civil SAR communities;

**6.1.10** Promote close cooperation among civilian and military authorities and organizations for provision of effective civil SAR services;

**6.1.11** Promote analysis and initiatives to help citizens avoid or cope with distress situations; and

**6.1.12** Consider, as appropriate, contingency plans for use of SAR resources in emergencies other than civil SAR.

## **7. PROCEDURES**

**7.1** The following procedures shall be followed in conducting the business of the Committee:

**7.1.1** The Committee shall schedule regular meetings on at least a [quarterly] basis.

**7.1.2** The Chair or any Member Agency via its respective Committee Member may call a special meeting when deemed necessary.

**7.1.3** Meetings will be properly documented by the Secretary. Decisions will normally be made by consensus. Where consensus cannot be reached, decisions will be submitted to the Committee for majority vote at a regular or executive meeting of the Committee, or by an informal poll of the Committee Members by the Secretary with the results properly documented.

**7.1.4** The Chair is authorized to represent directly the views, actions, recommendations and decisions of the Committee, or otherwise act on behalf of the Committee, by correspondence or other means, except that where such correspondence is directed to the [Secretary of Homeland Security] [Transportation], it shall be via the [name of national agency].

**7.1.5** The normal procedure for addition of a national Agency as an NSARC Member Agency and NSP Participant shall be as follows:

- i) Based on a unanimous vote of the Committee, the Chair will extend a written invitation to the prospective Member Agency, and the Agency will respond to the Chair in writing of the Agency's acceptance; and
- ii) The Chair will then notify each Member Agency, via the Member Agency's Executive Secretary or an individual designated to receive such notification, of the acceptance. If no Member Agency objects within [60] days, the invited Agency will from that time become a NSARC Member Agency and a NSP Participant. Such notifications, designations, and objections must be in writing.

**7.1.6** Alternatively, an additional national Agency may become a Member Agency and NSP Participant by mutual written agreement of all current Member Agencies and the prospective Member Agency.

**7.1.7** Termination of an Agency's Committee Membership shall automatically terminate its status as an NSP Participant; such termination shall be accomplished by the Agency's written notification to the other Member Agencies at least six months in advance.

**7.1.8** Policy issues or plans that require the attention or approval of the Signatories, e.g. adoption of the NSP, will be submitted by the Chair with recommendations for action. In such cases the views of all of the Committee Members shall be included.

**7.1.9** Nothing in this Agreement shall be viewed to obligate the Member Agencies to comply with decisions of the Committee.

## **8. ENTRY INTO FORCE, AMENDMENT, RENEWAL AND TERMINATION**

**8.1** This Agreement shall enter into force on the date of the first Committee meeting following the completion of the signatures by the Secretaries (or equivalent level authority) of all of the Member Agencies.

**8.2** Based on a unanimous vote of the Committee, any proposed amendment(s) to this Agreement or to the NSP must be adopted by one of the following means:

**8.2.1** The Chair will notify each Member Agency, via the Member Agency's Executive Secretary or an individual designated to receive such notification, of the proposed amendment(s). If no Member Agency objects within [60] days, the amendment(s) will be considered adopted. Such notifications, designations, and objections must be in writing.



**8.2.2** The amendment(s) shall be adopted by mutual written agreement of all Member Agencies.

**8.3** This Agreement, as amended, shall be automatically renewed on 1 January [year] and every five years thereafter unless superseded by a new arrangement or terminated.

**[Agency names and signatories]**

## PROPOSED AMENDMENTS TO IAMSAR MANUAL VOLUME II

### 1 Contents

- Add or amend text starting on page iii:

**2.18** ~~Inmarsat SafetyNET~~ Maritime safety information services

**2.19** Broadcast services

Renumber existing 2-19 through 2-33 as 2-20 through 2-34

**2.35** Additional device considerations

**2.36** RCC actions to consider

**2.37** Social media

- Renumber existing **Chapter 7** and **Chapter 8** as **Chapter 8** and **Chapter 9**
- Insert new Chapter 7:

### **Chapter 7 Multiple aircraft SAR operations**

**7.1** Overview

**7.2** Area of SAR action

**7.3** Aircraft coordinator

**7.4** Communications

**7.5** Search mission

**7.6** Evacuation missions

**7.7** Long range operations

**7.8** Effects of the environment and weather

Appendix T Multiple aircraft SAR operations

### 2 Abbreviations and Acronyms

- Delete the following text on page vii

~~**AES**.....aeronautical earth station~~

~~**GES**.....coast earth station~~

~~**GES**.....ground earth station~~

- Add on page xiii the following text:

**SLDMB**.....self-locating datum marker buoy

### 3 Glossary

- Delete the following text on page xi

~~**Coast earth station (CES)** — Maritime name for an Inmarsat shore-based station linking ship earth stations with terrestrial communications networks.~~

- Amend the Glossary as follows:

<b>Cospas-Sarsat System</b>	A satellite system designed to detect and locate activated distress beacons transmitting on in the frequency band of 406.0-406.1 MHz.
<b>Direction Finding (DF)</b>	<del>Homing on signals to pinpoint a position.</del> Radiodetermination using the reception of radio waves for the purpose of determining the direction of a station or object.
<b>Datum marker buoy (DMB)</b>	Droppable floating beacon used to determine actual total water current, or to serve as a location reference. There are two types, the radio type and the self-locating datum marker buoy type.
<b>Emergency Locator Transmitter (ELT)</b>	<del>Aeronautical distress beacon for alerting and transmitting homing signals.</del> A generic term (related to aircraft) describing equipment which broadcast distinctive signals on designated frequencies and, depending on application, may be automatically activated by impact or be manually activated.
<b>Fetch</b>	The distance the waves have been driven by a wind blowing over which the wind blows in a constant direction, without obstruction.
<b>Maritime Safety Information Service</b>	The internationally and nationally coordinated network of broadcasts containing information which is necessary for safe navigation.
<b>Maritime Safety Information (MSI)</b>	Navigational and meteorological warnings and forecasts and other urgent safety related messages broadcast to ships, as defined in regulation IV/2 of the 1974 SOLAS Convention.
<b>Page NAVAREA</b>	<del>One of 16 areas into which the world's oceans are divided by the International Maritime Organization for dissemination of navigation and meteorological warnings.</del> A geographical sea area established for the purpose of coordinating

	<p>the broadcast of navigational warnings. The term NAVAREA followed by a roman numeral may be used to identify a particular sea area. The delimitation of such areas is not related to and shall not prejudice the delimitation of any boundaries between States.</p>
<b>Personal locator beacon (PLB)</b>	<p><del>Personal radio distress beacon for alerting and transmitting homing signals.</del> A portable device, manually activated, which transmits a distress signal on 406 MHz, and may have an additional homing signal on a separate frequency.</p>
<b>Search and rescue point of contact (SPOC)</b>	<p><del>Rescue co-ordination centres and other established and recognized national points of contact which can accept responsibility to receive Gospas Sarsat alert data to enable the rescue of persons in distress.</del> A point of contact for SAR, designated by the national administration, that is responsible for receiving distress alert information and providing the information to the appropriate SAR authorities.</p>
<b><u>Self-locating datum marker buoy (SLDMB)</u></b>	<p><u>Droppable floating beacon, equipped with a global navigation satellite system (GNSS) sensor that transmits its location periodically, used to determine actual total water current, or to serve as a location reference.</u></p>
<b>Rescue co-ordination centre (RCC)</b>	<p>Note: The term RCC will be used within this Manual to apply to either aeronautical, maritime or joint centres; ARCC, MRCC or JRCC will be used as the context warrants.</p>
<b>Vessel Monitoring System (VMS)</b>	<p><del>A tracking system which provides for environmental and fisheries regulatory organizations to monitor position, time at a position, course and speed of commercial fishing vessels</del> Systems primarily used by environmental, fisheries and regulatory organizations, but also used by other organizations, to monitor the position, time of the position provided, course and speed of vessels</p>

#### 4 Chapter 1

- Amend page 1-2, paragraph 1.2.3(a), final sentence as follows:

The SMC plans the search and rescue operations and coordinates the transit of SAR facilities to and from the scene."

- Amend page 1-3, paragraph 1.2.4, 7th line as follows:

~~Conceivably, t~~ The OSC may have to assume SMC duties and actually plan the search and/or rescue if the OSC becomes aware of a distress situation directly..."

- Amend page 1-3, paragraph 1.2.4, bullets as follows:
  - assume operational coordination of all SAR facilities on scene;
  - receive the search and/or rescue action plan from the SMC;
  - modify the search action plan based on prevailing environmental conditions and keeping the SMC advised of any changes to the plan (~~do in consultation discuss~~ proposed modifications with the SMC when practicable);
  - provide relevant information to the other SAR facilities;
  - implement the search action plan;
  - monitor the performance of other units participating in the search operation; and
  - ~~— co-ordinate safety of flight issues for SAR aircraft;~~
  - ~~— develop and implement the rescue action plan (when needed); and~~
  - make consolidated reports (SITREPs) back to the SMC.
- Amend page 1-4, paragraph 1.3.2 as follows:

A list of potential SAR resources is contained in ~~the International Aeronautical and Maritime Search and Rescue IAMSAR Manual on~~ Volume I, *Organization and Management*."

- Amend page 1-8, paragraph 1.6.10 as follows:

Add to the end of the paragraph: A rescue action plan is also required.

- Amend page 1-8, paragraph 1.6.11, 3rd line as follows:

...ensuring that the search and rescue plans ~~is~~ are received, understood, and followed..."

- Amend page 1-13, paragraph 1.8.15 as follows:

Add Mass rescue operations to the subject matter list.

## 5 Chapter 2

- Amend page 2-5, paragraph 2.5.13, 4th line as follows:

... maritime safety information (MSI). Some Inmarsat ~~east earth stations (CESs)~~ LESs also offer EGC...

- Replace page 2-5, paragraph 2.6.7 with the following:

2.6.7 Cospas-Sarsat position information can be determined by several methods. The LEOSAR system uses a Doppler plot resulting from relative motion between the 406 MHz distress beacon signal source and the orbiting satellites. Alert messages provide two positions an equal distance on each side of the satellite track, and a confidence level (annotated as a percentage) to help in assessing which position is correct. Cospas-Sarsat is transitioning to a system (MEOSAR) which will calculate position based on time difference of arrival and frequency difference of arrival of the beacon signal at multiple satellites. This method will provide a single position. Some 406 MHz distress beacon messages may also include information derived from the Global Navigation Satellite System (GNSS). RCCs should consult the Cospas-Sarsat Handbook on Distress Alert Messages for Rescue Coordination Centres (RCCs), Search and Rescue Points of Contact (SPOCs) and IMO Ship Security Competent Authorities (C/S G.007, available on the Cospas-Sarsat website.) and other appropriate Cospas-Sarsat documentation for more information.

- Amend page 2-6, paragraph 2.6.9, first paragraph as follows:

2.6.9 In the original (LEOSAR) Cospas-Sarsat system, signals from 406 MHz distress beacons can be stored aboard a satellite and relayed to ground later if no LUT receiver is immediately within view of the satellite, enabling the system to operate in a global mode with fewer LUTs required. In the MEOSAR system which will augment the Cospas-Sarsat System, the signal from a 406 MHz distress beacon will be relayed through multiple satellites and received by an extensive network of LUTs providing near instantaneous notification and location of distress events.

- Amend page 2-6 paragraph 2.7.4, first line as follows:

2.7.4 Inmarsat type-approved ship earth stations (SEs) and aeronautical earth stations (AESs) transmit via the satellites to land earth stations (LESs), ~~also known as coast earth stations (CESs) for maritime functions and ground earth stations (GESs) for aeronautical functions.~~

- Replace section 2.10 **Mobile telephones – satellite and cellular** with the following:

## 2.10 Mobile telephones – satellite and cellular

2.10.1 Mobile (Cellular) telecommunications devices (such devices include basic mobile/cell phones; 'smart-phones'; 'Blackberry™' and similar devices; notebook; tablet and laptop computers using WiFi or telecommunications devices either as add-on or built in.) are in widespread use around the globe. Terrestrial mobile telecommunications devices can provide users with services such as telephone, text (Short Message Service – SMS), image (photo and video) capture and audio messaging – called Multimedia Message Services, email and data services (e.g. internet connection), and geographical position fixing and basic navigation capabilities (e.g. 'Satnav').

2.10.2 Mobile telecommunications devices can be used for reporting emergencies both at sea or on land. Cellular telecommunications are often easily available and familiar to users and can sometimes provide an effective signal over considerable distances on or near large bodies of water – depending on the location, height and power of the terrestrial aerial infrastructure.

2.10.3 A mobile/cell telephone can be a satellite or cellular telephone.

A satellite telephone communicates through satellites that can provide regional or global coverage.

A mobile phone (also known as a cellular phone, cell phone) is a phone that can make and receive telephone calls over a radio link. It does so by connecting to a cellular network provided by a mobile phone operator, allowing access to the public telephone network.

Many aspects of the guidance below regarding cellular telephones can also apply to the satellite telephone. Cellular telephones work well for point-to-point conversations within range of a supporting cellular network. Some cellular telephones can shift to satellite communications when they are moved outside terrestrial networks. However, these devices would have limitations in the maritime or remote environments, and therefore the advantages and use of dedicated marine and/or aviation communications and alerting systems should continue to be stressed by national administrations.

The following are some limitations which SAR authorities should make cellular telephone users in the aviation and maritime communities aware of, so that they see the advantages of using dedicated systems:

- use of a VHF radio in a distress situation for a MAYDAY call not only alerts SAR personnel, but other vessels, aircraft or stations within range, often enabling faster assistance from a variety of closer potential rescuers;
- the user must know or look up any needed telephone number if they want to use a cellular telephone for that purpose;
- radio signals can be used effectively to help locate survivors using either land or mobile DF equipment, but cellular telephones require close time-consuming coordination with service providers to identify the cell from which a call was placed (usually a 10-15 mile radius);
- VHF radios allow receipt of safety advisories, while cellular telephones do not;
- battery-powered cellular telephones are good for only a limited amount of talk time before batteries need to be changed or recharged;
- cellular telephone service providers can deny service to selected cellular telephones without advance notice (e.g. for late payment of fees);
- in disaster areas, cellular systems quickly become saturated with callers, making calls to others in the same area nearly impossible; and
- where installed, cellular phone coverage in the maritime environment can be limited, intermittent, or non-existent, based on several factors to include cellular tower accessibility and orientation in relationship to a cellular telephone call initiated from an offshore or coastal area.

**2.10.4** The services available to mobile telecommunications devices are provided over terrestrial radio systems which are connected to computer servers which record the activity, cell site connection and general locality of the user. This formation provides data which is of use to Search and Rescue authorities who may need to identify the location of persons in actual or possible danger e.g. overdue vessel, aircraft or persons on land.

**2.10.5** When receiving an alert via cellular telephone, SAR personnel should obtain the following information:

- caller's complete cellular telephone number;
- caller's cellular service provider;
- roam number if needed to recall the user;
- other means of available communications; and
- an alternative point of contact.

**2.10.6** The caller might be advised to ensure the phone is left on to receive further communications, or agree on a communications schedule. The caller might also be advised that the cellular number may need to be broadcast if an assistance broadcast is made. (Caution should be used in actually broadcasting the number, since this would enable anyone for any reason to call and tie up communications.)

**2.10.7** Survivors from distressed vessels, vehicles or crashed aircraft may be able to use mobile telecommunications devices to communicate in an emergency or call for assistance; or active devices may transmit occasional 'polling' emissions that could provide information as to the current location; or, the last activity of a device may provide a clue to calculate a last known position. Therefore, use of procedures to exploit location data from these devices to communicate with or determine the location of survivors can be important for effective SAR response, particularly when conventional means of communication or location information are not available or are inconsistent or inaccurate.

**2.10.8** Cellular service providers may be able to provide some of the following help in finding the position of callers in an emergency:

- call trace to the receiving cell while the call is connected, and an estimate of maximum range from the tower;
- approximate position based on the assessment of signal strength or time difference of arrival to several tower sites or from the cell phone's GNSS-derived positioning obtained either through direct means, in which a call is placed by the cellular user or by dialling the cellular number of the individual in distress (if known), or through indirect means via the phone's standby connectivity to the cellular network (provided the phone is powered on), which can be of particular use in instances where an individual may not be able to place or answer a call;
- cell tower location(s) of the last series of calls placed by the caller (useful for proximity searches), its associated traffic data, if available; and
- notification when a call is made from the user's number (useful in overdue cases).

**2.10.9** SAR authorities should make all appropriate arrangements (i.e. legal, logistic, etc.) with cellular service providers in their SRR to obtain the critical information in 2.10.8 in as quick a manner as possible and to establish regulations that require wireless providers to provide this information either through network-based or handset-based (e.g. built-in GNSS receiver) capabilities. Similar arrangements and protocols should also be made with emergency or public safety service agencies so that SAR-related emergencies may be directed to the appropriate SAR authority along with the caller's name, location, and other pertinent information when and where available.

**2.10.10** RCCs should provide all possible assistance to other RCCs requesting information about users of mobile telecommunications devices that are or may be in distress. This may include requesting information from communications service providers in their country on behalf of RCCs in other SRRs.



**2.10.11** National administrations should consider establishing free of charge, abbreviated telephone numbers to connect callers with emergency or public safety service agencies (e.g. "1-1-2", "9-1-1", "9-9-9") or direct cellular call connection numbers to SAR authorities (e.g. "1-6-1-6" in France and "1-5-3-0" in Italy) in order to provide emergency services and SAR authorities with an expedient means of notification from cell phone users in an emergency, and to publicize this information widely.

**2.10.12** Search planning techniques can be used in situations where a mobile telecommunications device can only be located using the terrestrial radio signal information obtained from the aerial site the device was or is connected to. Where Global Navigation Satellite Systems (GNSS) information is available on the location of a mobile telecommunications device (i.e. the user has a GNSS enabled device with positioning service activated), the SMC may simply be able to send a rescue unit to the reported position or apply normal Datum Point search planning procedures and techniques to the GNSS position. However, information on the signal-derived location may also be a useful corroboration of any GNSS position.

#### *Satellite Communications Services*

**2.10.13** Many mobile satellite communications services are not regulated for the provision of aeronautical or maritime distress alerting, nor are they suitable substitutes for approved means of distress communications. RCCs must still be capable of coordinating the response to incidents alerted via these services. There are numerous non-GMDSS international services (systems) used aboard aircraft and vessels for the provision of voice, fax, email, and data communications. Quite often these services automatically interface with public communications networks.

**2.10.14** Most satellite service providers maintain a network operations centre that is staffed 24/7. RCCs should maintain contact information for these centres to assist in establishing follow-on communications and obtaining vital data in the event of an alert being transmitted via one of their services. If an alert is transmitted via one of these services, either directly to a RCC or relayed to a RCC via another source, the SMC should then action the alert to resolve the incident.

- Amend page 2-13, paragraph 2.19.2, 2<sup>nd</sup> line as follows:

...continue to be voluntarily used ~~into the next century~~...

- Delete paragraphs 2.17.4 to 2.17.7 related to NAVTEX and WWNWS.
- Replace section 2.18 **Inmarsat SafetyNET** with the following:

#### **2.18 Maritime Safety Information Services**

**2.18.1** The World Wide Navigational Warning Service (WWNWS) is the internationally and nationally coordinated service for the promulgation of navigational warnings. Navigational warning means a message containing urgent information relevant to safe navigation, broadcast to ships in accordance with the provision of the International Convention for the Safety of Life at Sea (SOLAS), 1974, as amended.

**2.18.2** The two principal methods used for broadcasting maritime safety information (MSI), which include navigational warnings and meteorological information, in accordance with the provision of SOLAS are NAVTEX and SafetyNET.

**2.18.3** All NAVAREA, Sub-area and coastal warnings should be broadcast only in English in the international NAVTEX and SafetyNET services in accordance with IMO resolution A.706(17), as amended. In addition to the required broadcast in English, NAVAREA, Sub-area and coastal warnings may be broadcast in a national language using a national service.

- Insert new section 2.19 **Broadcast Services** before section **Radio Telegraph** as follows:

## **2.19 Broadcast Services**

**2.19.1** NAVTEX is used to promulgate navigation and meteorological warnings and other safety-related information to vessels and may be used by SAR services and for SAR purposes.

**2.19.2** International SafetyNET is used to promulgate navigation and meteorological warnings and other safety-related information to vessels and may be used by SAR services and for SAR purposes.

**2.19.3** Every RCC should make arrangements with an associated NAVAREA or National Coordinator to promulgate warnings on SAR-related information. Such information may include areas to be avoided or where search and rescue operations are being carried out.

**2.19.4** The International SafetyNET Manual describes the structure and operation of the International SafetyNET service. This includes examples and coding which must be followed for preparing SafetyNET broadcasts, including SAR broadcasts.

**2.19.5** It may be appropriate and advisable to promulgate distress alert relays over both NAVTEX and SafetyNET. All SOLAS ships and many fishing and other vessels sailing within NAVTEX coverage areas can be expected to carry 518 kHz NAVTEX receivers. Some may also carry equipment to receive SafetyNET broadcasts.

**2.19.6** Normally, the most practical way to handle SAR broadcasts over SafetyNET is to send them to all vessels within a desired radius of a specified position.

**2.19.7** The use of an all-ships broadcast to identify a vessel to divert for SAR operations should be considered as an initial action. It may require time to obtain responses from available vessels, and to select an appropriate one or more for the task, and can affect quite a few vessels. Although SafetyNET is a reliable, economical and important SAR tool, it must be used wisely. It is often prudent to supplement an all-ships broadcast with direct communications as a next step using vessels identified via LRIT, AMVER or another ship reporting system. Factors that may be considered when tasking vessels should include the location of vessels in relation to the incident area, relative ability of vessels to conduct a rescue and appreciation of the impact of diversions on the responding vessels.

- Renumber existing 2-19 through 2-33 as 2-20 through 2-34
- Add new section 2.35 **Additional device considerations** as follows:

## **2.35 Additional device considerations**

**2.35.1** These are additional devices that are seen in the maritime environment including those that are classified as a distress signal and/or locating device. These devices can include:

**(a) Radar SART (Search and Rescue Transponders)**

- Transmissions from these devices are classed as distress signals and visible to vessels and aircraft operating radar in the 9 GHz bandwidth
- Radar SARTs should activate an RCC's distress procedures and the appendix F - Distress Phase checklist

**(b) Devices with AIS component**

- Devices that have AIS locating capability include Man Overboard (MOB) devices, AIS SART and EPIRBS. These AIS devices are required to have an MMSI which is programmed by the manufacturer in a serialised manner. This MMSI is not connected with a vessel MMSI. Registration data may not be available but where it does exist it is strongly encouraged to be provided to RCCs..
- AIS SART (Search and Rescue Transmitters)

AIS-SARTs are part of the GMDSS and have been able to be used as an alternative to radar (X-band) SARTs. These are visible to AIS equipped vessels, and some shore stations (e.g. VTS) monitoring AIS. They are designated only as a locating signal and are intended to be used following transmission of distress alerting signals. However, as an AIS SART activation may be related to a vessel or person(s) that has activated a device to draw attention to their location because of an emergency situation that they could not make known by other means, it may need to be investigated.

**(c) AIS MOB (Man Overboard Device)**

- AIS Man Overboard (AIS MOB) devices are intended as personal locating devices for use by, for example, ship's crew members, offshore energy industry personnel, small boat users, divers, etc. These devices are small, portable and/or can be fitted to life jackets and personal flotation devices. AIS MOB devices transmit AIS locating signals in the same way as AIS SARTs.
- The sighting or reporting of an AIS MOB signal may indicate that a person or persons activated the device to draw attention to their location perhaps because of an emergency, for example, a man overboard from a vessel or offshore installation. The AIS MOB is primarily intended to enable the vessel, craft or installation from which a person has fallen, to locate them and for other nearby vessels to be able to assist if necessary.
- AIS MOB devices are used by small craft, for example, pleasure boats and small fishing vessels that may be operating single-handed or where crew numbers are small and so reports of AIS MOB sightings should be investigated.

**(d) EPIRB – AIS**

- EPIRB-AIS devices are 406 MHz distress alerting devices that contain an additional AIS transmitter developed using the same AIS-SART technology, where the AIS component is used as an aid in locating that EPIRB-AIS. EPIRB-AIS devices will be displayed in the same way as an AIS-SART.
- Add new section 2.36 **RCC Actions to consider** as follows:

**2.36 RCC actions to consider**

- a) RCCs should consider initiating Uncertainty Phase actions if an AIS signal is observed or reported to a RCC. This decision should be considered in conjunction with other available intelligence including but limited to other indications of a situation requiring a search and rescue response, local experience and considerations.
- b) Dependent on the decision to initiate a SAR phase the following additional action can be considered. If reported by a vessel:
  - Details and position of reporting vessel
  - Range and Bearing of radar SART transmissions or position of AIS SART
  - Vessels ability to proceed to position and ETA
- c) Other elements to consider:
  - When was SART transmission observed?
  - Are there any targets on radar or AIS in the direction of SART?
  - Check own AIS display (if available) for vessels in vicinity that can assist
  - If further search action is required conducting an electronic search for AIS SART/MOB devices, a sweep width should be calculated using IAMSAR Volume II, appendix N-10, Distance to Horizon formula:

$$\text{Horizon NM} = \sqrt{\text{Receiver height in feet}}$$

$$\text{Horizon Km} = \sqrt{\text{Receiver height in Metres}}$$

- Add new section 2.37 **Social media** as follows:

**2.37 Social media**

**2.37.1** Social media are not part of the international distress alerting system and is not monitored as a primary means of distress notification. However, the public uses social media to create online communities to share information, ideas, personal messages and other content. This can raise a public expectation that SAR authorities, especially for prolonged SAR incidences with news media interest, should either provide information to or accept information from social media sites.

**2.37.2** As a loosely-defined collaborative Internet network of hundreds or thousands of websites, there are no international protocols or policy to manage distress alerting via social media. The exchange of information on social media can occur real-time but often there is a lag time as participants enter and depart a website and commence and conclude their communication. Also, the large number of social media websites and associated time and personnel resource demands makes it impractical for SAR authorities and RCCs to monitor these websites.

**2.37.3** The SMC should be aware of the possible uses and RCC workload impact of social media in supporting a search and rescue response. These can range from the ability of persons to report information to family or friends as well as requesting intelligence from the community in regard to persons that are subject of a search and rescue response. SMCs should also be aware that social media may result in uncoordinated contributions and have the potential to distract SMCs from operational response, preventing effective coordination. SMCs should be able to rely on other resources to manage the operation of social media. This may be part of a coordinated national policy but at a minimum should be addressed within a SAR Authority's media policy. Also, commercial industry, such as passenger ship and airline companies may be making use of social media and, therefore, SAR authorities should collaborate on the flow of information with others that may be involved in a search and rescue response.

**2.37.4** Social media can be effectively utilized for disaster preparation, alerting and recovery, but this issue is different from distress alerting. For example, a designated disaster social media website can:

- (a) Support a disaster response when the responding/organizing authorities develop a social media website through which all distress notifications are received (The challenge is notifying the public of the existence of this specific social media website, and how to navigate to the site).
- (b) Provide relief to call centres during extended disasters which may receive large traffic volume.
- (c) Provide additional information critical to those in distress as well as those who are reporting persons in distress.
- (d) Provide a way for people to "leave messages" that may not reflect an urgent distress situation, but are still important and would allow SAR authorities to respond when able to the person posting the request.
- (e) Provide updated disaster response information on one website.
- (f) Provide information on what and to whom changes in situation(s) should be reported.
- (g) Provide information on who to contact to receive more information.

**Note:** *Care and caution should be adhered to during the use of information and material obtained from social media during response to SAR incidents*

**2.37.5** The SMC should make use of the capability of social media, as appropriate, but also should rely on other resources to manage the operation of social media. Also, commercial industry, such as passenger ship and airline companies may be making use of social media and, therefore, SAR authorities should collaborate on the flow of information with them.

## 6 Chapter 3

- Amend page 3-1, paragraph 3.1.2, 2nd line as follows:

during the first 24 hours...

- Amend page 3-6, paragraph 3.4.8, last sentence as follows:

This especially applies to when an initial Cospas-Sarsat alert where provides an A and a B position, the A and the B positions can be in different SRRs.

- Amend page 3-7, paragraph 3.5.6 (h) as follows:

Add additional text at end of current sentence:

Try to obtain information about persons in distress who may be carrying mobile telecommunications devices. Attempt to communicate with them by mobile/cell telephone call, text or email and/or contact the mobile communications service provider and request information about the device(s) last known location and use.

**Note:** Legislative restrictions may require that another agency have to undertake this task on behalf of the SAR services.

- Amend page 3-8, paragraph 3.5.9 as follows:

Add new bullet point after first bullet item:

If normal radio or satellite communications are unavailable or not connecting, and terrestrial telecommunications are likely to be within range, attempt or make calls, texts or emails to any distressed person(s) known to be carrying a mobile telecommunications device.

- Amend page 3-12, paragraph 3.8.5 (c) as follows:

(c) The probability of the search object remaining close to the position of the distress incident decreases with time. Floating search objects drift, and survivors on land may be walking. If the search object is mobile, the size of the search area must increase with time. Delay may dramatically increase search area size, possibly beyond what the available search facilities can cover. For survivors adrift in rapid water currents, the best chance of locating them is soon after they have gone adrift, while the search area is still small. For areas of high drift rate or whenever there is potential for an extended search for objects which drift, early deployment of one or more datum marker buoys, particularly self-locating datum marker buoys (SLDMB), can assist in determining the area to search and for relocating drifting objects.

- Amend page 3-12, paragraph 3.8.6 as follows:

Environment-related factors may severely limit available rescue time. Survivor life expectancy varies with the use of lifejackets, immersion suits, the type of clothing worn, the clothing's wetness, survivor activity, initial body temperature, physical and psychological condition, thirst, exhaustion, hunger, and will to live. Individuals can exceed common life expectancies or tolerance times. (Regarding survival in cold water, the IMO provides more information in its *Pocket Guide to Cold Water Survival*.) The following are guidelines, not absolute factors, for search planning and suspension. Expert medical advice should also be sought if available.

(a) Exposure to the chilling effects of cold air, wind, or water can result in hypothermia, the abnormal lowering of internal body temperature. The rate of body heat loss increases as air and water temperatures decrease. Death from hypothermia occurs ~~over four times more often in water than on land~~ more quickly in water than in air at the same apparent temperature. If possible, advise survivors not to enter the water, or to get out of it, even partially, if they are able to do so.

(b) The warmest ocean water that can be expected at any time of year is 29°C (84°F). About one third of the earth's ocean surface has water temperatures above 19°C (66°F). The term "cold" can be applied to water as warm as 25°C (77°F): long periods of immersion in water as high as this temperature can result in a fall in deep body temperature. It follows that most of the planet is covered in "cold" water.

(c) Wind is a factor for exposed survivors, as body heat loss accelerates with increasing wind velocity. Figure N-13 in appendix N shows the effects of various wind speed and air temperature combinations, and indicates the equivalent temperature on dry skin in still air. This emphasizes the need to shelter survivors who would otherwise be exposed to severe cold.

(d) ~~The warmest ocean water that can be expected at any time of year is 29°C (84°F). About one third of the earth's ocean surface has water temperatures above 19°C (66°F).~~ Figure N-14 in appendix N shows the realistic upper limit of survival time for people wearing normal clothing in water at various water temperatures, where "normal" means the clothing likely to be worn in the open in the circumstances; warm clothing in higher latitudes, light clothing in the tropics. The graph is based on the analysis of known survival cases and laboratory experimentation, ~~and shows a reasonable upper limit for search duration.~~ But it does not apply directly to people in additional protective clothing, nor to people who may have managed to get themselves wholly or partly out of the water: both might survive for longer times than the graph indicates. SOLAS survival suits are meant to keep a person alive for 24 hours in extremely cold water, for example. Neither should the graph be taken to imply that people in the water wearing normal clothing will survive for the time shown. Particularly at lower temperatures, many people in the water in normal clothing will survive for significantly shorter periods than the maxima shown in figure N-14. †The search planner must remember that this graph can only be indicative and that a number of uncertainty factors can improve or reduce survival time. It is a decision-making aid, not a decision-making tool.

(e) Guidelines based on analysis of accidents, together with laboratory-based experimental evidence, show a clear correlation between water temperature, body cooling and survival times. However, it is also apparent that, because of the ~~vast array of many~~ personal factors that can influence survival time in cold water, including cardiac problems and rapidly evoked responses ("cold shock") that result in early drowning, this time can vary from seconds to days.

Among the factors that slow the loss of body heat are:

- warmer water;
- calmer water;
- getting out of the water, or partial rather than full immersion
- good state of health;
- high body fat;

- heavy clothing;
- survival clothing;
- using a lifejacket or other flotation device (to minimize the need to exercise); and
- the use of protective behaviour.

Among the factors that make a person lose body heat faster are:

- gender (females are more prone to hypothermia);
- colder water;
- rougher or faster-flowing water;
- full immersion;
- injury / poor state of health;
- use of alcohol, non-medical drugs and most medications (which deregulate temperature control);
- age (children and the elderly are more prone to hypothermia);
- low body fat;
- light clothing;
- exercising (such as situations where persons without lifejackets have to swim); and
- seasickness.

There are other factors, and not all can be known to the search planner. Those listed here indicate the uncertainty that must be allowed for when referring to the graph in figure N-14.

Thus in water at 5°C (41°F), the 50% survival time for a normally clothed individual is estimated to be in the region of one hour, with a recommended search time of six hours. The corresponding times for 10°C (50°F) are two hours and twelve hours. While in water at 15°C (59°F) the 50% survival time is about six hours, with a recommended search time of 18 hours. Between 20°C (68°F) and 30°C (86°F)

It should also be noted that the graph in figure N-14 only extends to a maximum water temperature of 20°C (68°F). Above this temperature survival depends even more on individual circumstances and a "realistic upper limit of survival time" cannot be usefully determined. Search times exceeding 24 hours should be considered, and searching for several days should be considered for the highest water temperatures at the upper end of this temperature scale.

As there are many factors to consider, this model cannot be used for all situations. SOLAS survival suits are meant to keep a person alive for 24 hours in extremely cold water; and a person may be able to keep himself out of the water by climbing onto wreckage, for example. It should be kept in mind that factors working positively on survival times are often unknown to the SMC. Some of these factors include, but are not limited to, the following:



- Near-naked swimmers would be at the lower ranges of these survival times. But in calm water there may be an exceptional individual (someone who is very fat and fit) who will exceed expectations. If it is known that the victim is such an individual, consideration should, exceptionally, be given to extending the search times from 3-6 to 10 times the predicted 50% survival time.
- For inshore incidents, survival times may be less due to breaking water and adverse currents. However, consideration must be given to the possibility that the inshore survivor managed to get ashore. Consequently, the limiting effects of cold water cooling will no longer be the only consideration, and the search must be continued until the shore has been thoroughly searched.
- For offshore incidents, it is reasonable to expect that individuals may be better equipped to survive and have access to appropriate protective clothing and lifejackets and possibly liferafts. Consequently, search times for them should be at the upper limits of those expected (10 times predicted 50% survival time), unless obviously adverse conditions prevail – and should exceed them if it is possible that survivors may have been able to get out of the water.
- Survival time is shortened by physical activity (such as swimming) and increased by wearing heavy clothing and, if wearing a lifejacket, adopting protective behaviour (such as huddling with other survivors or adopting a foetal position in the water). Wearing a lifejacket or using some other flotation aid can increase survival time significantly. Lifejackets with a retaining system correctly attached (preventing body slippage) and a spray hood or splash guard (to protect the airway) are most likely to maximize survival. Survival time is also increased by wearing heavy clothing and/or adopting protective behaviour (such as huddling with other survivors, adopting a foetal position in the water, or getting partially or fully out of the water). Specialized insulated protective clothing (such as immersion suits or wet suits) is capable of increasing survival time from 2 to 10 times, depending on the type of clothing, whether there has been inadvertent water ingress, and sea conditions. The SMC should bear in mind that water ingress into an immersion/survival suit of as little as half a litre of water can reduce its insulation value by 30%, and that wave height of one metre can reduce it by additional 15%.

Predicting survival times in immersion victims is not a precise science; there is no formula to determine exactly how long someone will survive, or how long a search should continue. The SMC must make some difficult decisions based on the best information available, including expert medical advice, and on a number of assumptions, and should extend the search time beyond that to the maximum at which they anyone can reasonably be expected anyone to survive in the prevailing circumstances.

(e) The presence of certain forms of marine animals-life may increase hazards and reduce expected survival time. The SMC should be aware of what marine life may be in the search area and where to acquire specialized medical help quickly.

(f) Heat stress and dehydration are dangers in hot climates, particularly desert areas. The most severe form of heat stress is heatstroke, when body temperature rises. If the body temperature rises above 42°C (107°F) for sustained periods, death usually occurs. Dehydration is a critical factor both in hot climates and survival at sea; a person without water will die in a few days. A combination of high temperatures and lack of water will quickly aggravate heat stress and dehydration. In high-humidity areas, the water needs of the body are about one half those in deserts at equal temperatures.

- Insert on page 3-14, text on Areas of SAR Action after paragraph 3.8.8 as follows:

3.8.9 *Areas of SAR Action.* During SAR operations the SAR aircraft involved should be able to carry out their activities without interference from other air activity. Additionally, aeronautical organizations and aircraft not involved in a SAR operation, need to be made aware of it for their safety. The temporary establishment of appropriate areas surrounding SAR operations might improve safety and inform others of SAR activity.

An "Area of SAR Action" is an area of defined dimensions used or agreed by appropriate authorities for the protection of aircraft during SAR operations. It should be assumed that within areas of SAR action special flying procedures relevant to SAR operations might take place. Areas of SAR action are described in further detail in Volume II Chapter 7.

SAR organizations should arrange that RCC have methods in place for implementing areas of SAR action to facilitate SAR operations.

- Renumber existing 3.8.9 through 3.8.12 as 3.8.10 through 3.8.13

## 7 Chapter 4

- Amend page 4-4, paragraph 4.3.4 (a) as follows:

...it is usually obtained from the distressed craft itself or from external position fixing equipment (such as two or more lines of bearing from independent direction finding stations or positions provided by satellites, e.g. Cospas-Sarsat or from information obtained about mobile telecommunications device location and/or activity.

- Amend page 4-6, paragraph 4.3.5 as follows:

...based upon the navigational capabilities of the reporting source or the position-fixing estimates used by the SMC e.g. EPIRB, Satcom, radio direction-finding fix, position reports, mobile telecommunications devices location data, etc. and the distance travelled since the last navigational fix.

- Amend page 4-7, paragraph 4.4.4 as follows:

The best way to obtain wind and TWC information is through direct observation. One way to get such observations is from ships passing through the area. Such vessels should be asked to report set and drift as well as wind and other weather observations. If they are available, the observed movements of drifting buoys designed to have zero leeway and move with the surface currents can be used to determine TWC. ~~Some States maintain inventories of datum marker buoys (DMBs) which may be deployed by SRUs and either relocated by means of a radio beacon or tracked by satellite to measure surface currents.~~ Datum marker buoys have been mainly designed for use in determining total water current in the search area and for relocating drifting objects. There are buoys which can also provide elements of leeway. There are two primary sources for obtaining this type of information:

(a) SRUs, ships and aircraft, can deploy datum marker buoys (DMBs). There are two types of DMBs. The radio type DMB is located by radio direction finding from the SRU which must relocate the DMB for each current estimate (and send the DMB position and time back to the search planner). The self-locating DMB (SLDMB) uses GNSS technology to determine the buoy's position. It provides frequent, precise position information via satellite to a database for use by the search planner. This means that the SRU does not have to relocate the SLDMB or report its position. When using DMBs, search planners should use their best judgment to

estimate the area into which to deploy DMBs. For example, multiple or high currents in the probable search area are best handled by deploying several DMBs so as to gain a better picture of the influence of the current. Time is also a consideration. An incident in which the last known position is known and the time lag to DMB deployment is minimal, only a single DMB may be necessary. However, if a large time lag exists, or the last known position is not available, or there is potential for an extended search, then multiple DMBs should be used.

(b) Many other satellite-tracked buoys are adrift in the world's oceans in conjunction with various oceanographic studies. Unfortunately, there is no centralized database for identifying the principal investigator for a study and no mechanism for obtaining near-real-time observations for search planning purposes. However, it may be worthwhile to contact nearby universities or Government agencies engaged in oceanographic studies and determine whether they have, or can obtain, more accurate TWC information than that already available to the search planner. *Caution: Many drifting buoys used in oceanographic studies are drogued to move with sub-surface currents. Those that move with the upper one or two metres of the ocean measure total water current while those that are designed to move with deeper currents tend to measure only sea current.* Advance planning and an exchange of visits between search planners and nearby oceanographers would help in establishing ways to obtain near-real-time sea current data suitable for use in search planning.

## 8 Chapter 6

- Amend page 6-6, paragraph 6.8.3(b) as follows:

Add at the end of the subparagraph:

(Regarding recovery techniques, the IMO provides more information in its *Pocket Guide to Recovery Techniques*.)

- Amend page 6-14, paragraph 6.15.1 as follows:

Add at the end of this paragraph:

It is therefore necessary to plan to enhance SAR capability in MROs. Three means of doing so are to:

- agree to share SAR facilities regionally and/or internationally;
  - identify additional SAR facilities locally, including shipping in the area; and
  - extend survival time by providing support to persons in distress until they can be rescued.
- On page 6-14, add a new paragraph, 6.15.X as follows:

MROs will bring together organizations, at sea and on land, who do not usually work together. It is vital that these organizations communicate effectively at all stages – before and after an MRO as well as during it. Effective communications begin long before any MRO, at the planning stage, and also include post-incident analysis to improve arrangements based on the experience gained.

- Amend page 6-14, paragraph 6.15.2 as follows:

Add to the end of this paragraph:

It is therefore important to share, and to study, lessons learned in actual MROs and during the planning, training and testing phases of MRO preparation.

- Amend page 6-15, paragraph 6.15.6 as follows:

Add to the end of this paragraph:

It is therefore essential for as many potential MRO responders as practicable to plan and train together.

- Amend page 6-15, paragraph 6.15.10, 2<sup>nd</sup> sentence as follows:

...unusual levels of co-operation to achieve at the planning stage.

- Amend page 6-16, add text at the end of paragraph 6.15.14 as follows:

On-scene responsibilities for the safety of passengers and crew remain with the person in charge of the craft in distress while that person is still in command. During the rescue/recovery operation responsibilities for the safety of passengers and crew are shared by the person in charge of the craft in distress and the pilot in command or master of the rescue unit.

The pilot in command or master of each rescue unit has responsibility for the safety of survivors while they are on board the rescue unit.

- Amend page 6-16, paragraph 6.15.25 as follows:

Ship companies should be encouraged to equip large passenger ships and possibly other types of vessels with helicopter landing areas, or clearly marked hoist-winch areas, and onboard helicopters to facilitate more direct transfers of numerous persons."

- Amend page 6-16, paragraph 6.15.16 as follows:

Add at the end of the paragraph:

(Regarding recovery techniques, the IMO provides more information in its *Pocket Guide to Recovery Techniques*.)

- On page 6-17, add new paragraph 6.15.28 [bis] as follows:

If this approach is intended, it is essential that it is pre-planned, with full involvement of all parties, including the RCC staff, to avoid confusion at the time of an incident. The plan may, for example, provide for the RCC to maintain coordination of the SAR response while the higher operations centre handles the wider issues.

- Amend page 6-18, paragraph 6.15.32, 4th bullet as follows:

begin quickly with a high level of effort and stand down as appropriate rather than begin too late or with too little effort"

- Amend page 6-19, paragraph 6.15.36, last bullet as follows:

...Distress frequencies may be used for their initial response...

- Amend page 6-20, paragraph 6.15.48 by adding sentence at the end as follows:

Included in this are social media and awareness that industry, particularly airlines and passenger ship companies, may be making use of social media and, therefore, SAR authorities should collaborate on the flow of information with them.

## 6 Chapter 7

- Insert new chapter **Multiple Aircraft SAR Operations** as follows:

### Multiple Aircraft SAR Operations – General Guidance

---

#### 7.1 Overview

**7.1.1** The information in this chapter provides guidance for the management and conduct of multiple aircraft SAR operations. Any of the described principles and procedures might have to be modified by SMCs, ACOs and SRUs, in order to deal with specific situations. Further information on multiple aircraft SAR operations is available in IAMSAR volume III, section 5.

**7.1.2** Flight safety is a primary concern during any mission involving multiple SAR aircraft. SAR aircraft should be able to operate effectively and only the aircraft necessary for the mission should be involved.

#### *Number of SAR aircraft required*

**7.1.3** In any SAR operation, SMCs should consider the capabilities and the number of aircraft required. Too few aircraft in an operation might prove fatal for persons in distress, while too many can be difficult to organize and increase the risk of collisions. Other factors that might affect the number of aircraft required include the number of casualties, the carrying capacity of participating aircraft, weather conditions on scene, the distance of persons in distress from rescue facilities, the number of evacuation points, the speed at which an evacuation can take place, the speed of participating aircraft, the availability of refuelling facilities, the duration of an operation, aircrew fatigue and other operational factors. Where more aircraft than needed are available some can be held in reserve.

#### *Aircraft Capabilities*

**7.1.4** SMCs should consider how to match different aircraft capabilities to the circumstances and tasks required. For instance, fixed-wing aircraft might be excellent communications platforms and able to carry out searches and ACO duties, but are not capable of rescue hoist operations. SAR helicopters are flexible in their operations, but usually cannot fly as fast, as far, or as high as fixed-wing aircraft and generally need to refuel more often. Remotely Piloted Aircraft (RPA) might have useful reconnaissance and communications capabilities and be able to remain on scene for long periods of time, but some RPA also have a limited radius of operations. In general, for safety reasons, aircraft flown by aircrew and RPA should be kept well apart.

**7.1.5** SAR plans for multiple aircraft operations should be designed to achieve the most effective blend of aircraft and surface unit capabilities for the situations that are anticipated. SAR plans should aim to achieve continuous and efficient use of aircraft on scene when needed, while minimizing the situations in which aircraft are airborne without a mission.

**7.1.6** SMCs should consider the abilities of the crew and aircraft when planning and during operations, so that no tasks are beyond their abilities.

**7.1.7** Under some conditions, SAR aircraft might not be able to operate in accordance with SAR plans. Alternative plans should be developed and agreed in advance by SMC and pilots in command participating in the SAR-operation. Alternative courses of action during the mission should be agreed by pilot in command and SMC.

#### *Participation by other aircraft*

**7.1.8** In some situations, such as mass evacuations from offshore drilling platforms, large scale incidents over land areas etc., aircraft belonging to commercial companies or other organizations might be able to respond to incidents as part of existing emergency plans. During SAR operations, it is essential that the activities of these aircraft be coordinated with the overall SAR response in order to reduce the risk of collisions and to make the overall operation safe and effective. SAR authorities and SMCs should therefore make agreements with commercial companies and other organizations describing how SAR operations should be coordinated, when both SAR and other aircraft are involved. SAR authorities and SMCs should also be aware of the SAR requirements and capabilities of relevant companies and organizations in their SRRs.

#### *Refuelling Facilities*

**7.1.9** Use could be made of strategically located aircraft refuelling facilities that exist within range of an incident. Examples of suitable facilities include airfields, helicopter operating facilities, offshore drilling platforms and vessels that can refuel aircraft.

#### *Debriefing of SAR mission*

**7.1.10** Whenever a multiple aircraft SAR operation has taken place, a debrief should be held soon afterwards. The debrief should normally be conducted by the RCC in overall charge of coordinating the SAR operation. The debrief should include all the relevant units involved in the operation and record observations, lessons and recommendations to improve future SAR plans and operations.

## **7.2 Area of SAR action**

**7.2.1** During multiple aircraft SAR operations, SAR aircraft involved should be able to operate free from interference from other aircraft and operations.

#### *Definition*

**7.2.2** The term "area of SAR action" is derived from ICAO procedures for air navigation services (PANS-ATM). An area of SAR action is an area of defined dimensions that is established, notified or agreed for the purposes of protecting aircraft during SAR operations and within which SAR operations take place. There should be arrangement in place for SMCs to establish an "area of SAR action".

#### *Establishing Areas of SAR Action*

**7.2.3** The dimensions of the required area of SAR action depend on the circumstances and can be different over land compared to maritime operations. In general, the horizontal and vertical dimensions of an area of SAR action should be large enough to enable safe operations for SRUs, taking into account the need for airborne SRUs to safely manoeuvre throughout their

mission profile. SAR plans might involve procedures in which different altitude levels are assigned to different aircraft. This is an important consideration whenever any combination of fixed wing aircraft, helicopters and RPA are operating in the same area. Factors to be taken into account when considering the dimensions of areas of SAR action include the following:

- (a) The required extent of SAR activities, including searching.
- (b) The need for multiple aircraft to manoeuvre safely.
- (c) The need to protect SAR aircraft from other types of operations.
- (d) The impact that SAR activities might have on other, neighbouring activities.

#### *SAR Operations within Controlled Airspace*

**7.2.4** If multiple aircraft SAR operations take place within controlled airspace, then either the ATS should control SAR aircraft in accordance with normal ATS procedures or an agreed portion of airspace should be temporarily handed over for coordination by an ACO<sup>1</sup>. The ATS unit involved may also be in a position to carry out some of the duties of an ACO.

#### *Entry to Areas of SAR Action*

**7.2.5** SAR aircraft intending to enter an area of SAR action should not enter the area until the ACO gives them permission and provides them with sufficient information to safely join the flow of SAR aircraft involved in the operation (see also paragraph 7.4.2). Aircraft should call the ACO as early as possible before entering the area, in order to allow time for information to be exchanged and in case they are required to remain clear. As a general guide, aircraft should aim to get in touch with an ACO when at least ten minutes' flying time from the edge of an area of SAR action and pass entry information using the format described in appendix T. In the event that an area of SAR action has been established but an ACO is not yet available, SAR aircraft should receive information that they require from the coordinating RCC.

#### *Leaving Areas of SAR Action*

**7.2.6** Aircraft leaving areas of SAR action should contact the ACO before the area boundary and before changing to another frequency. Aircraft leaving should use the format described in appendix T.

#### *Flights in Areas of SAR Action by Other Aircraft*

**7.2.7** Aircraft that are not involved in a SAR operation should normally not fly within areas of SAR action. However, if such aircraft need to enter an area of SAR action, they should do so only with the approval of a SMC, ACO or coordinating ATS unit and are subject to the rules of the area or the relevant class of airspace. If a SMC or coordinating ATS unit is giving approval, the ACO should first be consulted.

### **7.3 Aircraft coordinator**

#### *Purpose of an ACO*

---

<sup>1</sup> This procedure might also involve the establishment of restricted or danger areas and the temporary suspension of controlled airspace.

**7.3.1** The purpose of an ACO is to contribute to flight safety and to perform an efficient SAR operation. The ACO should have a clear understanding of the aim of the SAR operation. ACOs should be prepared and able to coordinate SAR aircraft tasked by an SMC. Particular attention should be paid to aircraft that are likely to operate close to each other.

#### *ACO Qualification and Training*

**7.3.2** ACOs fulfil a vital function during SAR operations and their duties can be complex and require specialist knowledge. Therefore, ACOs need to have experience of relevant operations and exercises and be specially prepared for their duties. In order to ensure the best standard of SAR operations and safety, people likely to be designated as ACOs should be specially trained to carry out this duty. Once trained, SAR authorities should ensure that exercises take place to train ACOs and to practice multiple aircraft operations. RCCs should be aware of trained ACOs in their SRRs and establish procedures for tasking them whenever they might be needed for a SAR mission.

#### *Responsibility for Safety*

**7.3.3** Information from ACOs to aircraft on scene is advisory, but should nevertheless be followed as closely as practicable. If necessary to ensure flight safety, aircraft pilots-in-command should take whatever measures they assess are needed. If aircraft pilots-in-command deviate from advice passed by an ACO, then they should inform the ACO as soon as possible. The final decision concerning the safety of an aircraft, its crew and passengers rests with the pilots-in-command of the aircraft involved.

#### *ACO Duties*

**7.3.4** Procedures, duties and tasks involving ACOs are described throughout this Section. A list of normal duties for an ACO, also contained in IAMSAR Volume III, can include the following tasks:

- (a) **Contributing to flight safety:**
  - maintain a safe flow of aircraft
  - ensure use of a common altimeter setting for all aircraft involved
  - advise the SMC of on-scene weather implications
  - determine a direction for entering and leaving areas of SAR action
  - determine all points necessary for maintaining a safe flow of aircraft within the area of SAR action
  - filter radio messages to and from SAR aircraft
  - ensure frequencies are used in accordance with SMC directives
  - coordinate with adjacent air traffic services (ATS) units
- (b) **Prioritizing and allocating tasks:**
  - ensure SAR aircraft are aware of the SMC/OSC overall plan and their own tasks



- monitor and report search area coverage
  - with appropriate SMC/OSC, identify emerging tasks and direct SAR aircraft to meet them.
- (c) Coordinating aircraft operations:
- respond to changing factors on scene and supervise effectiveness of operations
  - ensure the continuity of aircraft operations in coordination with SMC/OSC
- (d) Informing SAR aircraft:
- Assign tasks to aircraft
  - Distribute relevant flight
  - safety information to aircraft (see subparagraph (a) above)
  - Provide information about relevant air activity and dangers on scene
  - Provide information about search areas (if applicable) evacuation points (if applicable) and refuelling facilities.
  - Provide operational information about the ongoing SAR-mission
  - Provide relevant weather information.
- (e) Make periodic situation reports (SITREPs) of SAR aircraft operations to the SMC and the OSC, as appropriate.
- (f) Work closely with the OSC:
- assist in the execution of SMC directives
  - maintain communications
  - advise on how the ACO can assist.
- (g) Coordinate aircraft refuelling.

#### *Designating an ACO*

**7.3.5** Whenever two or more aircraft are taking part in a SAR operation and are likely to operate close to each other, SAR authorities should consider designating a person, unit or organization as an ACO.

**7.3.6** An ACO is designated by a SMC and should carry out missions under a SMC's direction.

SMCs should consider designating an ACO as soon as they recognize that a SAR incident might need a response from two or more aircraft. ACOs should be notified of their mission as early as possible, in order to give them the maximum time to prepare for their tasks.

**7.3.7** There are many factors for SMCs to consider when designating an ACO, however, some significant considerations are as follows:

- (a) Designating an ACO should be considered when two or more aircraft are involved in a SAR mission.
- (b) An ACO should be equipped with appropriate forms of communication for the SAR mission, such as the appropriate radios for communicating with aircraft, with ATS units, with SAR authorities and with SRUs on the surface.
- (c) An ACO should clearly understand the overall objective of the SAR operation and relevant SMC plans.
- (d) ACOs should be provided with sufficient information to carry out their mission or have access to sufficient information.
- (e) An ACO should know which authority to report to (normally a SMC) and which other units are involved in a mission.
- (f) ACOs should be able to reach the required location in sufficient time for them to prepare for and carry out their duties.
- (g) A person or SAR unit designated as an ACO should have received appropriate training beforehand.
- (h) An ACO should be familiar with the types of aircraft involved and their flying operations.
- (i) An ACO should be familiar with SAR operations involving multiple aircraft.
- (j) ACOs should ideally be familiar with the environment, normal procedures, activities and air traffic systems in the areas of operation.
- (k) The time that ACOs may be available to carry out their missions should be considered. If an ACO is on board an aircraft, then aircraft endurance might limit the amount of time for which that ACO can be available.

#### *ACO Location*

**7.3.8** ACOs should ideally be as close to the scene of a SAR incident as practicable. However, the choice of location of an ACO is flexible, and they should operate in locations which best help them to carry out their duties, such as on a fixed-wing aircraft, a helicopter, a ship, a fixed structure such as an oil rig, an ATS unit, a coordinating RCC or another appropriate land unit.

#### *ACO Workload*

**7.3.9** The workload of an ACO can be very high. SMCs should bear this factor in mind, when they are considering the total number of SRUs that might be required for a SAR operation.

### *Coordination with Adjacent Facilities*

**7.3.10** As much as possible, SMCs should aim to reduce an ACO's workload by coordinating SAR activities taking place within an area of SAR action, with relevant ATS units, airfields and other facilities. However, depending on the location and circumstances of an incident, ACOs should also be prepared to carry out these duties.

### *On-Scene Altimeter Setting*

**7.3.11** A common altimeter setting should be used by all aircraft within an area of SAR action. This altimeter setting might be determined when the first SAR aircraft equipped with a radio altimeter arrives on scene. Alternatively, the on scene altimeter setting can be determined by the ACO, in consultation with an ATS unit (when available) a SMC or an OSC (when appropriate). The ACO should pass the information to all aircraft in the area of SAR action.

### *Reporting On Scene Activity*

**7.3.12** The ACO should make regular reports of on scene activity to the SMC and aircraft involved in the SAR operation. When possible, these reports should be made when ACOs or aircraft are not busy with other operational tasks. The radio communications procedures described in paragraph 7.4.2 can be used for this purpose; however, other methods might also be appropriate. A general guide is for ACOs to make reports every thirty minutes during a SAR operation.

### *Information from SAR Aircraft to the ACO*

**7.3.13** In order to enhance situational awareness for ACOs and other SAR aircraft and to assist with safety and the continuity of operations, participating aircraft should report as follows:

- (a) Entry report.
- (b) Reaching assigned points.
- (c) Leaving assigned points.
- (d) Commencing operations (search, investigation during search, approach to the surface/ship, missed approach, hoist, landing etc.).
- (e) Completing operations, including information regarding results.
- (f) Leaving present altitude.
- (g) Reaching new altitude.
- (h) 30 minutes on scene endurance, expecting fuel at (location).
- (i) 10 minutes to completing hoist operation.
- (j) 10 minutes to completing search.
- (k) Exit report.

### *Transfer of ACO tasks*

**7.3.15** During some SAR operations, particularly those lasting for long periods of time, it may be necessary to transfer the tasks from one ACO to another. This might be due to fatigue, factors affecting an ACO's location, such as the requirement for an ACO's aircraft to refuel, or for other reasons.

**7.3.16** Before accepting the task the new ACO should understand the details of the SAR mission and the SMC's plans. The details required include the aim of the operation, the position of the missing object, number of persons in distress, other units involved, locations of participating aircraft, communications and any limitations to the operation. When possible, basic pre-flight information should be provided by a SMC in order to simplify the transfer to the new ACO. Examples of information that might be of use to ACOs on scene can be found in are in appendix T - 3

**7.3.17** A new ACO will need enough time to obtain information, study it and then prepare to accept the task from the previous ACO. Every SAR mission may be different, but as a general guide, a handover of information should begin approximately thirty minutes before a new ACO formally takes over.

### *When to Conclude ACO Operations*

**7.3.18** A SMC is normally in charge of a SAR mission and determines which SRUs take part in it. However, in practice, an ACO is often in the best position to advise the SMC, when a SAR operation no longer requires an ACO. The decision to end ACO operations should normally be made by the SMC that designated the ACO, after consulting with relevant organizations and units.

### *Checklists and Guides*

**7.3.19** Units who are likely to be designated as ACOs or take part as airborne SRUs in the event of a multiple aircraft SAR operation, should always have ACO checklists or guides available whenever they are on duty. Guides and checklists suitable for ACOs are contained in appendix T.

### *Reference Information for Air Crew*

**7.3.20** SAR authorities should ensure that all air crew likely to become involved in multiple SAR operations are aware of the procedures. To help with this process, air crew should routinely operate and fly with reference information, including IAMSAR Vol III, in case they are required to take part in an operation at short notice. Additionally, a short reference list known as the "Pilot Information File" (PIF) contains information useful for all aircraft involved in multiple aircraft operations and is illustrated in appendix T - 6 and also in IAMSAR Volume III.

## **7.4 Communications**

### *Radio Voice Communications*

**7.4.2** There should be agreed, common, on scene procedures for the following:

- (a) On Scene Coordination Frequency. An agreed coordination frequency for radio voice communications should be used within an area of SAR action. This frequency should be one which all aircraft can access, together with the ACO. Information that should be passed between an ACO and SAR aircraft is listed in appendix T.

- (b) Alternative Frequencies. Alternative frequencies should also be nominated by an ACO, if the agreed coordination frequency is likely to become too busy or unusable.
- (c) Capabilities. Care should be taken to ensure that aircraft and surface units involved in an operation are capable of complying with the communications procedures.
- (d) Communications with an OSC. Consideration should be given to enabling communications between an ACO and an OSC. However, it should not normally be necessary for SAR aircraft other than an ACO to communicate directly with the OSC.
- (e) Radio Communications Failure Procedures. All SAR plans for multiple aircraft SAR operations should include procedures for use when radio communications fail. A failure of radio communications might affect aircraft, SRUs or persons in distress individually, or might involve a compromise of radio systems affecting several participants. The systems affected might include radio voice communications or radio systems designed to indicate the positions of aircraft, vessels or people, including transponders and other devices. In general, the following principles should apply to most situations in which radio communications fail:
- A backup means of radio voice communication should be determined and then nominated by an ACO, along with the normal communications plan.
  - The backup radio voice communications might include alternative frequencies, alternative radio communications systems or both. In the event of a radio communications failure, with no alternative airborne communications available, aircraft should normally continue with their planned timings, events and flight path, still transmitting all position and altitude reports, until they are clear of the immediate on scene area.
  - If an aircraft has not been given a plan when a radio communications failure occurs, then it should avoid the on scene area, departing by an appropriate route and heights.
  - Once clear of the on scene area, aircraft should consider moving near or landing at a suitable facility in order to establish communications by alternative methods.

**7.4.3** If radio voice communications cannot be restored, then alternative procedures could be considered such as increasing the distances between aircraft using time. If not already included in SAR plans, then all participating airborne SRUs might have to be assembled together in order for this procedure to be briefed and understood. In most cases, this would result in considerable delays to a SAR operation.

**7.4.4** A diagram illustrating a basic example of communications during multiple aircraft SAR operations, involving an ACO is described in appendix T-2.

#### *Long Range Radio Communications*

**7.4.5** Communications systems designed for long range SAR operations can be different from the types of communications used at shorter ranges. Types of radio equipment that relies

on direct 'line of sight' between a transmitter and receiver may not be suitable for long range communications between SMCs and SRUs. Some long range communications methods include the following:

- (a) High Frequency radio systems.
- (b) Satellite communications systems.
- (c) Position tracking systems, including those that enable two-way communications.
- (d) The use of high flying aircraft to relay VHF radio communications to and from lower flying SAR aircraft.
- (e) Relay of information to and from SAR aircraft through ATS units.
- (f) Relay of information by ships at sea able to communicate with SAR aircraft on marine band VHF frequencies, whilst a shore based RCC uses satellite, MF or HF communications to communicate with the relaying ship(s).
- (g) Relay of information by any surface units able to communicate with both SRUs and SMCs.

## **7.5 Search mission**

### *Safety and Search Effectiveness*

**7.5.1** ACO and SAR aircraft should use procedures that ensure flight safety, without making the search ineffective. Aircraft should be given sufficient operational freedom to carry out their searches effectively, but should conform to safety procedures briefed by the ACO.

**7.5.2** Methods used to safely keep aircraft apart will depend on the on scene conditions. Beginning with good weather conditions and progressing to poor conditions, methods for keeping aircraft apart can be as follows:

- (a) Visual Methods.
- (b) Flow Methods.
- (c) Coordination Zones.
- (d) No Fly Zones.

### *Visual Methods*

**7.5.3** Visual methods involve the ACO allocating aircraft to search areas and aircraft avoiding each other visually. Visual methods may be the only measure necessary when weather conditions on scene are good. When using visual methods, the ACO can allow aircraft more freedom of action compared to other, more restrictive, methods. However, this freedom will not relieve aircraft or ACOs from other duties outlined earlier in this section, for example providing information on air activity or making aircraft reports.

### Flow Methods

**7.5.4** Flow methods can be used to keep SAR aircraft apart in slightly poorer conditions, by ensuring that they fly the same search patterns (commence search point /line of advance, etc.) but in adjacent search areas. The first aircraft on scene should be allocated the search area furthest away from the line of advance. This method enables aircraft to execute effective searches of areas with a minimum of radio communication. Aircraft can also be kept apart by using time. This method could be used if aircraft arrive on-scene at considerably different times, for example as a result of departing from different base locations.

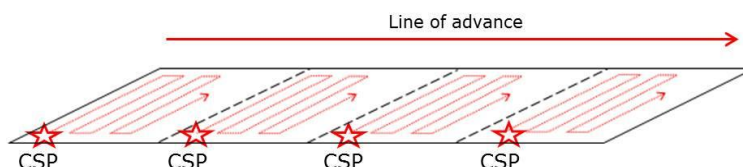

**7.5.5** The ACO may order specific search altitudes for SRUs, to allow an extra margin of safety when aircraft operate in close proximity to each other. However, in this situation the ACO should be aware that any limit to the operational freedom of an aircraft, particularly in altitude, could reduce the effectiveness of the search. The ACO should also expect aircraft to deviate from their assigned altitude if they need to investigate objects on the surface. ACOs should ensure that all aircraft use the same reference for altitude.

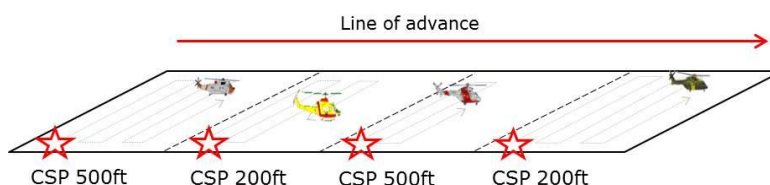

### Coordination Zones

**7.5.6** Coordination zones are border areas established by an ACO between adjacent search areas, which SAR aircraft can only enter under specific conditions. Coordination zones enable aircraft to have operational flexibility within their allocated search areas and ensure a level of safety between them.

**7.5.7** The dimensions of a coordination zone depend on the on-scene conditions and the size of a search area. As a general guide a coordination zone might be 2 nautical miles across, but this size may be increased or decreased if needed. Before entering a coordination zone, aircraft sharing the zone should communicate with each in order to safely coordinate the entry. The ACO should ensure that the aircraft have a clear understanding of their mutual operating areas. The aircraft should call again when leaving the zone.

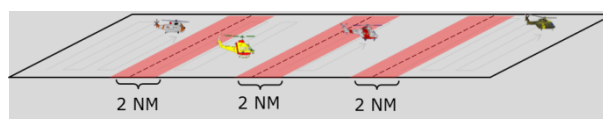

### No Fly Zones

**7.5.8** If on scene conditions are sufficiently difficult, no fly zones can be used in which flight is not permitted while searching is taking place in adjacent areas. The dimensions of no fly zones can be similar to coordination zones. Whenever no fly zones are used, the ACO should

coordinate with the SMC and OSC to ensure that the zones are searched appropriately during the SAR mission.

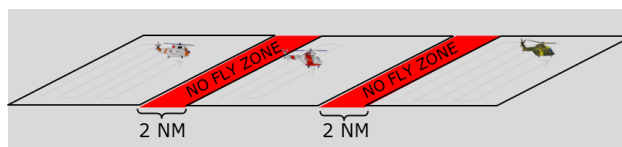

## 7.6 Evacuation missions

### *Safety Flow Procedures*

**7.6.1** The main aim of on scene procedures for multiple aircraft operations should be safety. In general, there are two methods that can be used to ensure a safe flow of SAR aircraft, which are as follows:

- (a) *Horizontal Spacing.* Horizontal spacing of aircraft should be the basic method used by SAR authorities and ACOs. It can be achieved by establishing specific routes to be flown by SAR aircraft to, from and within the area of SAR action.
- (b) *Vertical Spacing.* For situations in which keeping aircraft apart horizontally will not ensure sufficient levels of safety, or if a cross-over of aircraft flight paths cannot be avoided then, when weather permits, vertical spacing should be considered. It may not always be necessary for SAR aircraft to fly at different altitudes, unless they are likely to fly close to each other or their flight paths cross over. If a significant possibility of collision exists, then different altitudes should be assigned for SAR aircraft.
- (c) In general, altitudes for RPAs should be kept apart from altitudes allocated for other SAR aircraft.

**7.6.2** Ideally, the most effective method to ensure a safe flow of aircraft is by using a combination of both horizontal and vertical spacing. The best way to achieve this is through planning by an ACO and a clear understanding of procedures by all of the units and authorities involved.

### *Aircraft Approach and Departure Flight Paths*

**7.6.3** Approach and departure flight paths are usually influenced by the prevailing wind direction; factors which might also have to be taken into account are:

- (a) Fumes directly downwind from burning structures may be unsafe – the direction of approach for aircraft might have to be off-set from the wind direction.
- (b) Geographic features or the design of the casualty location might compel aircraft to approach only from specific directions. Structures such as cranes, towers or vertical obstructions in line with the wind direction, might be dangerous.
- (c) ACOs and SAR aircraft should be aware of all surface vessels, installations or other obstructions in the approach and departure sectors and plan to avoid them.



## **7.7 Long range operations**

**7.7.1** Long range is any distance that significantly limits or compromises the ability of SAR aircraft to operate on scene effectively and safely.

### *Long Range Procedures*

**7.7.2** When flying long distances, SAR aircraft should attempt to reduce fuel consumption while in transit, to provide for more additional time on scene. It might be necessary for SAR aircraft to fly as directly as possible to and from an incident, with the result that multiple aircraft SAR procedures have to be modified and rely on basic safety arrangements. These arrangements could include separate arrival times on scene and basic inbound and outbound height differences in order to keep aircraft safely apart. Additional considerations for long range SAR communications are described in paragraph 7.4.5

**7.7.3** The risks to SRUs during long range SAR operations should be considered carefully before long range SAR operations take place, including the following:

- (a) Overall urgency to save life.
- (b) Range offshore.
- (c) Nature of the mission.
- (d) Performance characteristics and technical limitations of aircraft taking part in the mission.
- (e) Communications.
- (f) Availability and effectiveness of flight following equipment: satellite tracking; ATS radar picture, etc.
- (g) Likelihood of locating the relevant person in distress, vessels or platforms.
- (h) The risk to SRUs in the event of an accident.
- (i) Current and forecast weather conditions en route and on scene.
- (j) Sea state/ swell.
- (k) The amount of darkness on scene (at night).
- (l) Size, shape and characteristics of the casualty vessel, platform or location.
- (m) Location of persons in distress on a vessel (e.g. should they be moved to a suitable position for rescue hoist operations).
- (n) The proximity of refuelling facilities to the persons in distress.
- (o) The availability of diversions or locations for temporary landing (e.g. offshore energy installations, etc.)
- (p) Aircrew capabilities or skill levels.
- (q) Aircrew fatigue.

### *Bringing a Casualty Vessel Within Range*

**7.7.4** If the casualty is on a moving vessel, SMCs should consider the possibility of directing it to move to a point within the effective range of SAR aircraft or other forms of assistance. Alternatively, it might be possible for SAR aircraft to refuel at locations that effectively bring a casualty within their maximum radius for SAR operations. It could also be effective for SMCs to use both of these options at the same time.

## **7.8 Effects of the environment and weather**

**7.8.1** Factors such as the type of environment and weather can significantly affect the conduct of multiple aircraft SAR operations. It is important that SAR authorities establish plans that contain procedures for all of the weather conditions likely to be encountered. As a general principle, it is usually better to plan for poor conditions and to then modify procedures if better conditions permit. As weather and environmental conditions become worse, the risks for both the persons in distress and rescuers increase and the speed at which SAR operations can take place becomes slower.

**7.8.2** Some weather conditions might prevent certain types of SRU from operating, while other types of SRU can still continue. For example, conditions such as very poor visibility at sea might limit or prevent airborne SRUs operations, but might not prevent surface rescue craft from operating. Heavy seas might make ship to ship transfers of persons in distress unacceptably dangerous, while helicopter hoist operations can continue. Poor weather conditions at airfields, places of safety, along coastlines or along an intended route can affect SRUs and prevent them from departing for, or fulfilling their SAR missions.

**7.8.3** In extreme situations the risks to SRUs and persons in distress of attempting a SAR operation might be sufficiently high that operations cannot take place at all, until conditions improve. There are many factors that can affect multiple aircraft SAR operations; several of the more common ones are outlined below.

- (a) *Wind Direction – General.* Wind direction can have a strong influence on search patterns flown by aircraft and the directions of approach and departure by aircraft to persons in distress. Generally, approaches and departures by aircraft are flown into wind. Geographic features, characteristics of the casualty vessel or structure, might mean that approach and departure directions have to be modified. Additionally, if the location of persons in distress is on a burning structure, then smoke and fumes may be dangerous. Airborne SRUs should avoid flying directly downwind of the source. The wind direction might have a significant influence on a SAR operation and multiple aircraft SAR procedures should be designed with this principle in mind.
- (b) *Strong Winds – Maritime Operations.* Strong winds can present significant difficulties for aircraft, whether operating on their own or together with other aircraft. During maritime operations, rescue attempts from surface vessels with large amounts of movement due to heavy seas can be extremely dangerous. Strong winds and high sea states can affect even the largest vessels, sufficiently to prevent helicopters from landing on helicopter decks. Strong winds can also make rescue hoist operations extremely difficult. Air turbulence downwind of large vertical structures such as offshore platforms, wind farms or the superstructures of large vessels can be dangerous for aircraft operations.

- (c) *Strong Winds – Moisture and Atmosphere.* Strong winds can significantly affect transit times for aircraft and might limit the ranges at which they can operate. Moisture from the sea can be stirred up into the atmosphere at least 1000 ft above sea level. This moisture can decrease visibility and in very cold conditions can cause ice to build up on aircraft structures. Moisture that has a high salt content can also reduce aircraft engine performance enough to limit the amount of people and cargo that can be carried and make aircraft operations unsafe.
- (d) *Strong Winds – Over Land Operations.* Strong winds over land can result in turbulence in the air that is dangerous for aircraft. Turbulence can be particularly severe in mountainous areas, near cliffs and for significant distances downwind of hills and mountains. In very strong winds, horizontal visibility is usually reduced; this is most noticeable both in and downwind of dry, dusty regions such as deserts. A similar, but usually more local affect can take place in snow-covered regions. Multiple aircraft SAR operations can be significantly affected by such events and may not be able to take place at all until conditions improve.
- (e) *Low Cloud and Poor Visibility.* Low cloud can reduce visibility and restrict the amount of altitude in which SAR aircraft can manoeuvre. Low cloud and poor visibility also reduce the effectiveness of SAR operations or even prevent them altogether.
- (f) *Adjusting SAR Plans.* Some SAR authorities have plans for multiple aircraft operations that enable them to operate in conditions of poor visibility, sometimes relying on ATS units and good levels of training. During maritime operations, some aircraft are themselves capable of finding and flying to vessels in conditions of very poor visibility. This procedure may only be possible if carried out by aircraft and aircrew capable of this type of flying. At the very least, poor visibility will significantly slow down the speed at which multiple aircraft operations can be conducted, compared with operations in good weather. In many situations, low cloud and poor visibility may prevent multiple aircraft SAR operations from taking place at all, until conditions improve.
- (g) *Darkness.* During darkness distances are more difficult to visually assess than during daylight and aircraft often need to maintain greater horizontal and vertical spacing from each other.

#### *Night Vision Devices*

**7.8.4** Night vision devices are often being worn by SAR aircrew, as they can compensate for the effects of darkness. When used appropriately, night vision devices significantly improve safety and effectiveness over land as well as in coastal and maritime operations.

**7.8.5** Although using night vision devices can improve multiple aircraft SAR operations, these devices can be affected by the weather conditions at night in a similar way that visual flying can be affected by day. Night vision devices also need at least a small amount of light in order to work adequately.

**7.8.6** The amount of darkness at night is affected by many factors, including the amount of moonlight, cloud and lighting made by human activity, such as structures and buildings. All authorities and units involved in SAR operations in which night vision devices are used should be aware of the effect that weather and light conditions can have on their performance. In very

dark conditions, such as when there is no moon at all and significant cloud, night vision devices may be of little use during a SAR operation.

*Effect of Artificial Lighting on Night Vision Devices*

**7.8.7** Night Vision systems can be adversely affected by powerful sources of artificial lighting, such as searchlights and pyrotechnic flares used by SRUs. These light sources should not be used without prior warning or agreement with SAR aircraft on scene.

- Renumber existing chapters 7 and 8 to chapters 8 and 9

Amend page B-11 as follows:

**Suggested format for alert information from a commercial locating, tracking and emergency notification service provider to an RCC**  
(Format based upon Cospas-Sarsat standard format)

Field No.	Field Name	Field Content	Field Format
1	SEND Alert	SEND Distress Alert	Header
2	Reporting Centre	Call Center Identity	Agreed alphabetical abbreviation for Call Center (e.g. "GEOS")
3	Message Number	Unique Message Number	Call Center Abbreviation followed by unique message number assigned by call center (e.g. GEOS/12345)
4	Message Date	<del>Year-Month-Day</del> <del>Day Month</del> Year in the Gregorian calendar	<del>YYYY-MM-DD</del> <del>DD MMM YY</del> where <del>YYYYDD</del> is the year day, <del>MMM</del> is the month annotated with the first three letters of the month of the year between 01 (January) and 12 (December), and <del>DD YY</del> is the last two numbers of the year day of the month between 01 and 31
5	Message Transmit Time	Hours:Minutes:Seconds in Coordinated Universal Time (UTC)	<del>hh:mm:ssZ</del> <b>hh:mm:ssZ</b> UTC where hh is the number of complete hours that have passed since midnight (00-24), mm is the number of complete minutes that have passed since the start of the hour (00-59), ss is the number of complete seconds since the start of the minute (00-60) and Z indicates the use of UTC time.

Field No.	Field Name	Field Content	Field Format
6	Local Time (optional)	Hour:Minutes:Seconds in local time of where device is located	<del>hh:mm:ss(Local)</del> where hh is the number of complete hours that have passed since midnight (00-24), mm is the number of complete minutes that have passed since the start of the hour (00-59), <del>ss is the number of complete seconds since the start of the minute (00-60)</del> and Local is replaced with EST, CST, MST, PST or other local time zone abbreviation. Abbreviation shall include Daylight saving time if applicable.
7	Message Type	New Alert or Update (if later include original Message No)	"New" or "Update" as appropriate plus for updates the original message number as per Field #3
8	Destination Responsible SAR Authority	Message Destination	Identity of the SAR Authority that the message is intended for in English
9	Message Source ID	Message Identifier	If alerting device message identifier is different to the message number in Field #3 then insert it here otherwise leave this field blank
10	Device ID	IMEI Number (the 15 digit International Mobile Equipment Identity (IMEI) number of the device)	<b>AA-BBBBBB-CCCCC-D</b> where AA-BBBBBB are the Type Allocation Code (TAC) for the device, CCCCC is the manufacturer assigned serial number of the device and D is the Luhn check digit
11	Device Manufacturer and Model Number	Identity of the device sending the distress alert	Device Manufacturer and Model Number (e.g. SPOT Satellite GPS Messenger)
12	Satellite System	Identity of the carrier of the distress alert	Identity of satellite system used (e.g. Globalstar, Inmarsat, Iridium)
13	Message	Complete Message	The complete text of the message as transmitted by the device
14	Latitude	Latitude in Degrees and Decimal Minutes in WGS84 format	<del>sDD° MM.MMM's</del> where <del>s</del> indicates if the latitude is North "N" or South "S" of the equator, DD indicates the number of degrees and MM.MMM indicates the number of minutes and decimal parts of minutes of latitude (to an accuracy of approximately 2m (6ft)), and <del>s</del> indicates if the latitude is North "N" or South "S" of the equator

Field No.	Field Name	Field Content	Field Format
15	Longitude	Longitude in Degrees and Decimal Minutes in WGS84 format	<del>s</del> DDD° MM-MMMs' where <del>s</del> indicates if the longitude is East "E" or West "W" of the prime meridian, DDD indicates the number of degrees and MM-MMM indicates the number of minutes and decimal parts of minutes of longitude (to an accuracy of approximately 2 m (6ft)), and <del>s</del> indicates if the longitude is East "E" or West "W" of the prime meridian
16	Position Source and Accuracy	Location provided by GPS, Doppler etc and estimated accuracy of location	Location source (e.g. GPS, Glonass, Doppler) and estimated location accuracy in Meters (e.g. GPS: 10 m)
17	Optional Position Movement and Height	If available speed and course over ground (SOG and COG) and height above sea level	<b>SSS:CCC:HHHHH</b> where SSS is the speed over ground (SOG) in Knots (from 1 to 999), CCC is the track made good (Course over Ground (COG)) in degrees (from 1 to 360) relative to True North and HHHHH is the elevation above ground (Height from 1 to 99999) in Meters. If any field is not available leave blank
18	Device Database Source	Identity of Where Database Containing User Contact Details Held	Full address and phone numbers (including country, postal/zip code and international telephone dialling codes)
19	Registered Name	Name of SEND Owner	Full name of registered SEND owner
20	Registered Address	Owners Address	Full address of SEND owner including country and postal/zip code
21	Registered Phone Numbers	Owners Phone Numbers	Phone numbers including full dialling codes for all phones registered by the Owner including land line and mobile/cell phone
22	Emergency Contact Details 1	Full Name, Address and Telephone Numbers for first emergency contact	Full name, address and phone numbers (including country, postal/zip code and international telephone dialling codes)
23	Emergency Contact Details 2	Full Name, Address and Telephone Numbers for second emergency contact	Full name, address and phone numbers (including country, postal/zip code and international telephone dialling codes)

Field No.	Field Name	Field Content	Field Format
24	Supporting Information	Medical, Vehicle, Trip Plan, Numbers in party, etc.	Free text field, in which to provide any additional data that may be of use to SAR
25	Call Center Contact Details	Full Address and Telephone Numbers for Call Center	Full address and phone numbers (including country, postal/zip code and international telephone dialling codes)
26	Call Center Operative	Name of the person handling the alert at the call center and their direct telephone number	Full name and phone number (including extension if applicable)
27	Remarks	Any additional information that the Call Center has on the situation	Free text field
28	End Message	End of Message	Message Ends

[FROM COMSAR 17]

- Amend page B-15 as follows:

**Sample of alert from a commercial locating, tracking and emergency notification service provider to an RCC**

\*\*\*Alert from a commercial locating, tracking and emergency notification service provider to an RCC\*\*\*

Reporting Centre : GEOS  
 Message Number : GEOS/12345  
 Message Date : ~~2011-12-31~~ 31 DEC 11  
 Message Transmit Time : ~~21:13:39Z~~ 2113 UTC  
 Local Time (optional) : ~~15:13:39~~(EST)1513 (EST)  
 Message Type : Update to GEOS/12344  
 SAR Authority : Jackson County, OR. Sherriff's Department  
 Message Source ID :  
 Device ID : 49-015420-323751-8  
 Device Manufacture/Model # : SPOT Satellite GPS Messenger  
 Satellite System : Globalstar  
 Message : "as sent by SEND device"  
 Latitude : ~~N42°-06.935'~~42 06 935 N  
 Longitude : ~~W122°-42.340'~~122 42 340 W  
 Position Source and Accuracy : GPS:10m  
 Speed:Course:Height (optional) : 010:034:00500  
 Device Database Source : GEOS  
 1234 Sends Road  
 Springfield, TX. 60092 USA  
 +1 908 145 8389  
 Registered Name : John Smith  
 Registered Address : 3450 Twin Cedar Drive  
 Ashland, OR 97563 USA  
 Registered Phone Number : (541) 772 5899  
 Emergency Contact Details (1) : Jane Smith  
 3450 Twin Cedar Drive  
 Ashland, OR 97563 USA

Home (541) 772 5899  
Cell (541) 458 9273  
Emergency Contact Details (2) : Jack Smith  
8800 Mountain View Drive  
Phoenix, OR 97543 USA  
Home (541) 544 5637  
Cell (541) 634 9545  
Supporting Information : "Free text field in which to provide any additional data that may be of use to SAR forces"  
Call Center Contact Details : GEOS  
1234 Sends Road  
Springfield, TX. 60092 USA  
+1 908 145 8389  
Call Center Operative : Max Jones +1 908 145 8389 ext 342  
Remarks : "Any additional information on the situation"  
\*\*\*\*\* END MESSAGE \*\*\*\*\*

## 7 Appendix C

- Amend page C-1, insert new 6th bullet beneath the similar text concerning OSCs as follows:

test capabilities of potential ACOs and ability to transfer ACO duties;

- Amend page C-1, 8th bullet ("coordinate activities and achieve information exchanges"), 1st sub-bullet as follows:

...RCC-OSC-ACO..."

- Add at page C-4, 3rd paragraph, at the end of 3rd bullet:

(A means of rescue is a requirement for ro-ro passenger ships, and ships on international voyages are required to have ship-specific plans and procedures for recovery of persons from the water.)

- Amend page C-4, 3rd paragraph, 9th bullet as follows:

provide on board helicopter landing or winching areas and helicopters;

- Amend page C-4, 3rd paragraph, 10th bullet as follows:

prepare to assist survivors ~~once~~ until and after they have been delivered to a place of safety;"

- Amend page C-7, 'MRO communications in a maritime

incident', 1st paragraph as follows:

It needs to be established from the outset ~~which frequency could include relations to the media (refer to Contact with the media in section 2 of the IAMSAR Manual, volume III)~~

## 8 Appendix F

- Amend appendix F, bullet 19 as follows:



- 19 Have ATS unit alert *en-route* aircraft and consider establishing a temporary Area of SAR Action.

Amend page I-4, as follows:

## Maritime Search and Rescue Recognition Code (MAREC Code)

### General

1 The purpose of this Code is to facilitate the communication of essential descriptive information regarding merchant vessels and small crafts within and between maritime SAR organizations services.

2 The MAREC Code is in two parts:

- Part 1 — Merchant vessels
- Part 2 — Small crafts

3 All messages should be preceded by the prefix MAREC followed by a local serial number, assigned by the RCC.

4 The message should contain all the lettered identification groups as separate paragraphs. If the information is not known, the symbol UNK should be inserted or alternatively the symbol NA, where the lettered group is not applicable.

5 When sending Email, Fax, SMS or some other electronic messages, there is no guarantee that the recipient receives the message or that the message is being processed.

### Part 1 – Merchant vessels

The message is composed of the following identification groups and will be transmitted in the following sequence:

#### MAREC – Local serial number

- A. Type of vessel – name – call sign or ship station identity
- B. Superstructure – location – colour
- C. Hull profile – colour
- D. Sequence of uprights
- E. Length
- F. Condition of loading
- G. Other characteristics

#### A. *Type of vessel, name and call sign or ship station identity*

Merchant ships are classified as follows:

<b>Voice</b>	<del>TLX</del> <b>Electronic</b>
Passenger ship	PAX
Ferry	FERRY
Tanker	TANK

Bulk carrier	BULK
General cargo ship	GEN
Coaster	COAST
Fishing vessel	FISH
Containership	CONT
Specialized ship	SPEC

The name and call sign, or ship station identity, are added to the above classification. For specialized vessels, the specific type of vessel should also be given, as appropriate, e.g. gas carrier, tug, or icebreaker.

Example:

**Voice:** ALFA, SPECIALIZED SHIP GAS CARRIER, FLYING DRAGON, CHARLIE GOLF HOTELINDIA

**TLXElectronic:** A/SPEC/GAS CARRIER/FLYING DRAGON, CGHI

### **B. Superstructure: Location and colour**

Superstructures are referred to as being located forward, midships or aft or a combination of these positions, and may be described as long or short.

Colour is given in plain language.

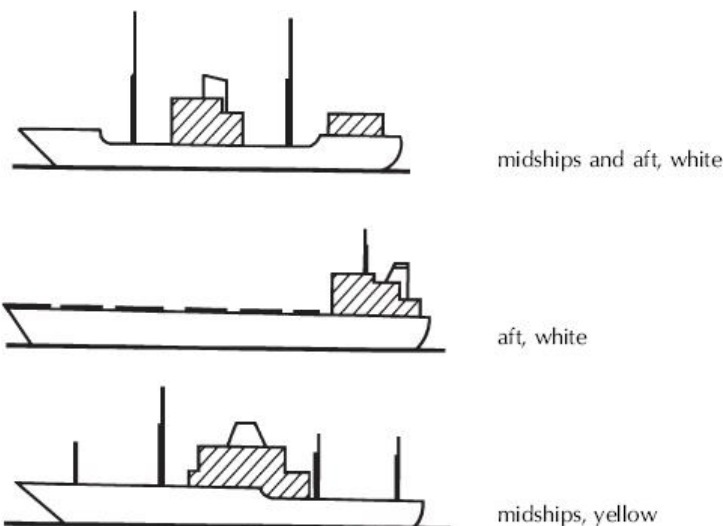

Example:

**Voice:** BRAVO, SUPERSTRUCTURE MIDSHIPS AND AFT, WHITE

**TLXElectronic:** B/MIDSHIPS AND AFT/WHITE

### **C. Hull profile and colour**

The hull profile is divided into three sections, numbered 1, 2 and 3 from stem to stern.

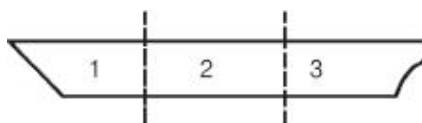

The existence or otherwise of raised sections (other than superstructures) above the main weather deck of the vessel should be reported numerically as follows:

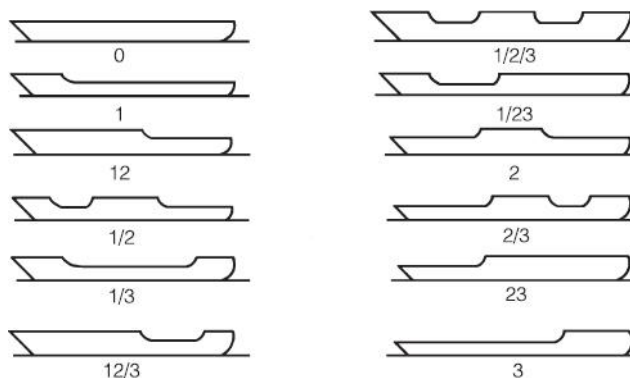

The colour of the hull is given in plain language.

Example:

**Voice:** CHARLIE, PROFILE ONE TWO SLANT THREE, BLACK  
**TLXElectronic:** C/12/3 BLACK

#### D. Uprights

Uprights include everything, other than the profile and superstructures, which is prominent and can clearly be seen at a distance. The uprights are reported from stem to stern according to the list below:

<b>Voice</b>	<b>TLXElectronic</b>
Mast	M
Kingpost	K
Funnel	F
Crane	C
Gantry	G

Uprights located close to a superstructure such that they cannot be clearly seen from a distance should not be included. Double kingposts located athwartships (perpendicular to vessel's centreline) are reported as one kingpost.

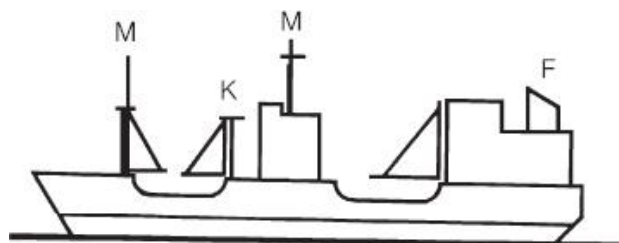

Example:

**Voice:** DELTA, MAST, KINGPOST, MAST, FUNNEL  
**TLXElectronic:** D/M K M F

#### E. Length

Length is the length overall (LOA) given in metres.

**Note:** Length can be estimated by observing the vessel's lifeboats, which are normally about 10 metres long, in proportion to the ship's length.

Example:

**Voice:** ECHO, TWO ZERO METRES

**TLXElectronic:** E/LOA 20

#### F. **Conditions of loading**

The conditions of loading are indicated as follows:

<b>Voice</b>	<b>TLXElectronic</b>
Light	LIGHT
In ballast	BALL
Partially loaded	PART
Fully loaded	LOAD

Example:

**Voice:** FOXTROT, PARTIALLY LOADED

**TLXElectronic:** F/PART

#### G. **Other characteristics**

Other prominent characteristics should be given, e.g. stack insignia, conspicuous deck cargo or other distinguishing marks or colour variations, e.g. name in big letters on vessel's side or company insignia painted on side of hull. In the message, such specific characteristics should be given in full.

Example:

**Voice:** GOLF, RAILROAD CARS ON DECK

**TLXElectronic:** G/RAILROAD CARS ON DECK

#### **Complete Example**

The following illustrates a typical merchant vessel and how it would be described in a message according to this system.

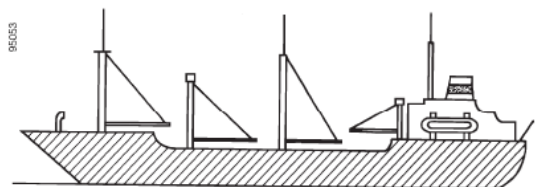

**Voice:** MAREC, 45/761/10\_RCC STOCKHOLM SWEDEN RESCUE  
ALFA, GENERAL CARGO SHIP, VIKING, ECHO SIERRA DELTA CHARLIE  
BRAVO, SUPERSTRUCTURE AFT, WHITE  
CHARLIE, PROFILE ONE SLANT THREE, BLACK  
DELTA, MAST, KINGPOST, MAST, MAST, FUNNEL  
ECHO, EIGHT FIVE METRES  
FOXTROT, LIGHT  
GOLF, NOT APPLICABLE

**TLXElectronic:** MAREC 15/761/10 RCC STOCKHOLM SWEDEN RESCUE  
A/GEN/VIKING/ESDC  
B/AFT/WHITE  
C/1/3/BLACK  
D/M K M M F  
E/LOA 85  
F/LIGHT  
G/NA

## Part 2 – Small craft

The message is composed of the following identification groups and will be transmitted in the following sequence:

MAREC – Local serial number

- A. Type of craft/number of hulls – name – call sign or ship station identity – use
- B. Make – distinctive markings
- C. Motor installation or rigging
- D. Construction – material – colour
- E. Stem – stern
- F. Type of bottom
- G. Length
- H. Other characteristics
- I. Number of persons on board

**A. *Type of small craft/number of hulls, name, call sign or ship station identity and use***

**Voice ~~TLXElectronic~~**

Motor open MOTO  
Motor part cabin MOTPC  
Motor full cabin MOTFC  
Rowing ROW  
Sailing open SAILO  
Sailing part cabin SAILPC  
Sailing full cabin SAILFC  
Motor sail MOTSAIL  
Inflatable INFLAT

Where the number of hulls is more than one, this should be indicated by adding the words or group as follows:

Two hulls – Catamaran CAT

Three hulls – Trimaran TRI

The craft's name, call sign or ship station identity and use should be added to words or groups above. Under *use* indicate the purpose for which the craft is being used, e.g. fishing, pilot boat, or offshore racer.

Example:

**Voice:** ALFA, MOTOR PART CABIN CATAMARAN, LUCKY LADY, NAVIS  
ONE THREE, PLEASURE

**TLXElectronic:** A/MOTPC/CAT/LUCKY LADY/NAVIS 13/PLEASURE

**B. Make and distinctive markings**

The make and distinctive markings should be given in plain language.

Example:



**Voice:** BRAVO, MAKE STORTRISS, SAIL MARKINGS TWO OVERLAPPING TRIANGLES WITH POINTS UP AND NUMBER SIERRA ONE THREE EIGHT

**TLXElectronic:** B/STORTRISS/SAILMARKINGS TWO OVERLAPPING TRIANGLES POINTS UP/S138

**C. Motor installation or sail rigging**

*Motor installation*

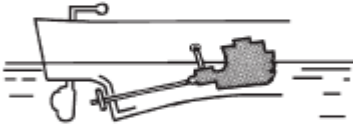
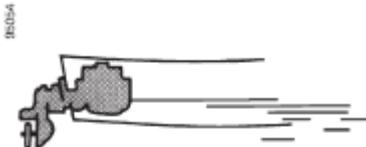





The motor installation is given according to the figures shown below.



	<b>Voice</b>	<b>TLXElectronic</b>
	Outboard motor, if applicable, with the addition	OUTB
	Double or Triple	OUTB 2 OUTB 3
	Inboard motor	INB
	Aquamatic, if applicable, with the addition	AQUA
	Double	AQUA 2

*Rigging (sailing boats)*

Type of rigging is described on sailing boats and motor sailers according to the figures below. (If there is more than one mast, this is indicated by the appropriate number.)

	<b>Voice</b>	<b>TLXElectronic</b>
	Jib rig	JIB

	<i>Voice</i>	<i>TLXElectronic</i>
	Sprit rig	SPRI
	Gaff rig	GAFF
	Lug sail	LUG
	Lateen rig	LAT
	Sloop rig	SLOOP
	Junk rig	JUNK
	Yawl	YAWL

	<b>Voice</b>	<b>TLXElectronic</b>
	Ketch	KETCH
	Schooner	SCHON

Example 1:

**Voice:** CHARLIE, OUTBOARD MOTOR, DOUBLE

**TLXElectronic:** C/OUTB 2

Example 2:

**Voice:** CHARLIE, SLOOP RIG

**TLXElectronic:** C/SLOOP

#### **D. Construction – material – colour**

##### *Construction*

Two different types of construction exist, viz. clinker-built and carvel-built or smooth-sided.

*Note:* Some glass fibre boats are moulded to resemble clinker-built and should be so described in this Code.



Clinker



Carvel

##### *Material*

The materials are wood, metal or glass-reinforced plastic (GRP). Construction, material and colour should be given in plain language.

Example:







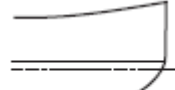

**Voice:** DELTA, CLINKER, GLASS FIBRE, WHITE

**TLXElectronic:** D/CLINKER/GRP/WHITE

#### **E. Stem – stern**

Stem and stern are described according to the figures shown below.

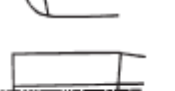

	<b>Voice</b>	<b><i>TLXElectronic</i></b>
	Straight stem	STR
	Clipper stem	CLIP
	Falling stem	FALL
	Flat stern	FLAT
	Square stern	SQUARE
	Sharp stern	SHARP
	Canoe stern	CAN
	Transom stern	TRANS
	Negative transom stern	NTRANS





Example:

**Voice:** ECHO, FALLING STEM, CANOE STERN

***TLXElectronic*:** E/FALL/CAN

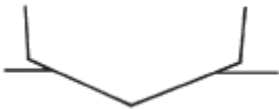
**F. Type of bottom**

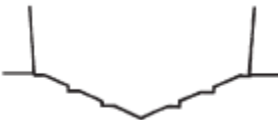
Type of bottom is described according to the figures shown below.

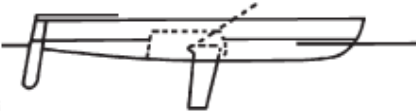
	<b>Voice</b>	<b>TLXElectronic</b>
	V-bottom	VBOT
	Flat bottom	FLAT
	Round bottom	ROUND
	Ribbed bottom	RIB
	Keel	KEEL
	Fin- keel(where double fin- keel, add the word "double")	FIN
	Centre-board	CB

Example:

**Voice:** FOXTROT, RIBBED BOTTOM

**TLXElectronic:** F/RIB

**G. Length**

Length is the length overall (LOA) given in metres.

Example:

**Voice:** GOLF, TWO ZERO METRES

**TLXElectronic:** G/LOA 20

## H. *Other characteristics*

Other characteristics should be included to describe certain details that might facilitate identification, e.g. flying bridge or spinnaker sail colouring.

Example:

**Voice:** HOTEL, RED SPINNAKER

**TLXElectronic:** H/RED SPINNAKER

## I. *Number of persons on board*

Example:

**Voice:** INDIA, THREE

**TLXElectronic:** 1/3

### Complete Example

**Motorboat**

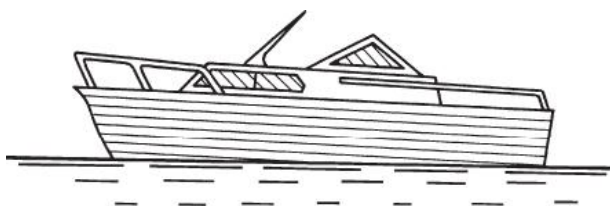

**Voice:**

MAREC ~~7763~~ 3/10, RCC STOCKHOLM STAVANGER

ALFA, MOTORBOAT PART CABIN, GALANT, NAVIS ONE THREE, PLEASURE

BRAVO, MAKE SOLOE TWO FIVE

CHARLIE, INBOARD MOTOR

DELTA, CLINKER, GLASS FIBRE, WHITE

ECHO, FALLING STEM, SQUARE STERN

FOXTROT, V-BOTTOM

GOLF, SEVEN AND A HALF METRES

HOTEL, PULPIT FORWARD

INDIA, UNKNOWN

**Electronic:**

MAREC ~~776~~ 3/10, RCC STOCKHOLM STAVANGER

A/MOTPC/GALANT/NAVIS 13/PLEASURE

B/SOLOE/25

C/INB

D/CLINKER/GRP/WHITE

E/FALL/SQUARE

F/VBOT

G/LOA 7.5

H/PULPIT FORWARD

I/UNK

**Complete Example**

**Sailing boat**

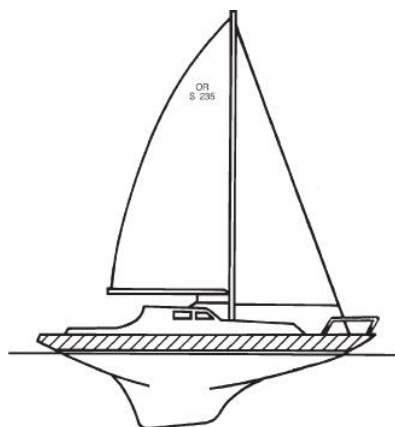

**Voice:**

MAREC 8/76 4/10, RCC ~~GOthenburg~~ SWEDEN RESCUE

ALFA, SAILING PART CABIN, ARABESQUE, NAVIS ONE TWO, PLEASURE

BRAVO, MAKE VIVO TWO ZERO, SAIL MARKINGS LETTERS OSCAR ROMEO SIERRA TWO THREE FIVE

CHARLIE, SLOOP RIG

DELTA, CARVEL, WOOD, BLACK WITH WHITE CABIN

ECHO, FALLING STEM, NEGATIVE TRANSOM STERN

FOXTROT, KEEL

GOLF, EIGHT METRES

HOTEL, PULPIT FORWARD

INDIA, TWO

***TLXElectronic:***

A/SAILPC/ARABESQUE/NAVIS 12/PLEASURE

B/VIVO 20/OR S 235

C/SLOOP

D/CARVEL/WOOD/BLACK WITH WHITE CABIN

E/FALL/NTRANS

F/KEEL

G/LOA 8

H/PULPIT FORWARD

I/2

## 9 Appendix K

- Amend appendix K, K.2.4, 7<sup>th</sup> line, as follows:

...a line of bearing for the distressed position or mobile telecommunications device data which may help indicate present or past location or area... can be established which may eliminate some scenarios.

[FROM NCSR 1]

## Appendix N

Amend Figure N-14 on page N-19, as follows:

Figure N-14<sup>†</sup> – *Realistic upper limit of survival time for people in the water wearing normal clothing, from time of entry into the water.* (~~See Volume II, chapter 3 for details.~~)

[Footnote:] <sup>†</sup> ~~Based on expert medical opinion and the latest scientific data.~~ Note that this graph does NOT show a 'recommended search time'. There are many factors to take into account in determining search time. See Volume II, chapter 3.8.6.

## 10 Appendix T

Insert Appendix T after Appendix S, as follows:

### Appendix T

#### Checklist for multiple aircraft SAR operations

Checklist for Multiple Aircraft SAR Operations	T-1
Example Radio Communications Plan	T-2
ACO Procedure Form-Mass Rescue Operations	T-3
Briefings	T-4
SAR Aircraft Entry and Exit Reports	T-5
Pilot Information File	T-6

### Checklist for Multiple Aircraft SAR Operations

The Checklist below is for example purposes and for general guidance only. Each SAR operation is different therefore not all of the items below might be needed and additional ones might be required. Some items might also be carried out by different facilities and units from those indicated below.

SERIAL	TASK	ACO	SMC	ATS	SRU
1	Declare Emergency Phase		X		
2	Identify Requirement for ACO		X		X
3	Designate and Notify ACO	X	X		
4	Inform ATS units & Establish Area of SAR Action		X	X	
5	Identify Aircraft And Capabilities	X	X		
6	Develop and Promulgate Plan	X	X		X
7	Establish Co-operation with OSC	X	X		
8	Co-ordination with ATS	X	X	X	X
9	Manage Aircraft Activities	X	X	X	
10	Call ACO before Entering Area	X			X
11	Call ACO when leaving Area	X			X
12	Monitor and Update On Scene Plan	X	X		
13	Provide Regular Situation Reports	X	X		
14	Manage Fuel & Numbers of airborne SRUs	X	X	X	X
15	Stand Down or Relieve the ACO	X	X		
16	Cancel/ Terminate the SAR Operation	X	X	X	X
17	Cancel Area of SAR Action	X	X	X	X

**Notes:**

1. 'X' signifies action required or the receipt of information
2. For the purposes of this checklist, 'SRU' refers to aircraft involved in the SAR operation.

### Example Radio Communications Plan

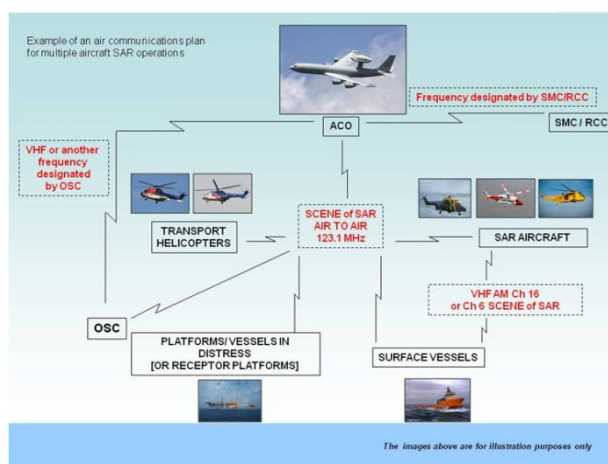

### ACO Procedure Form-Mass Rescue Operations

GENERAL INFORMATION	
OPERATION	
EMERGENCY LOCATION	
IDENTIFICATION (VERSION)	
TIME ZONE	
ACO INFORMATION	
ACO FREQUENCY	
ACO TEL / EMAIL	
WAYPOINTS	
REFERENCE POINT	
EXIT POINT	
HOLDING POINT	
HOLDING POINT	
HOLDING POINT	
EVACUATION SITE	
EVACUATION SITE	
REFUELING/CREW SUPPORT	
ALTITUDES	
ENROUTE/ENTRY	
HOLDING POINT(S)	
EXIT POINT	
ENROUTE/LEAVING AREA	
NATURE OF DISTRESS AND/OR SEARCH OBJECTS	
SAFETY BRIEF	
<p><i>"The Air Coordinator will only provide advisory information. You (the Aircraft Commander) are responsible for the safety of your own aircraft at all times. If you, because of safety reasons, are unable to comply with instructions given by ACO, you are to notify me (ACO) immediately."</i></p>	
PICTURE OF ACO PROCEDURE	
MISSED APPROACH PROCEDURE	
OPERATIONAL INFORMATION	
COMM PLAN	WEATHER ON SCENE + QNH
ACO 123,100 RCC/OSC CH SHIPS CH OTHER	WIND VIS CLDS TEMP QNH

### Briefings

**The ACO should ensure that the following information is briefed to the SAR aircraft after check in and when appropriate**

<b>SAFETY BRIEF</b>	"The Air Coordinator will <u>only</u> provide advisory information. You are responsible for the safety of you own aircraft at all times. If you because of safety reasons are unable to comply with instructions given by the Air Coordinator , you are to notify me immediately"
<b>QNH/ALT.</b>	Which reference is used for common altimeter setting?
<b>ORGANISATION ON SCENE</b>	Who is acting Aircraft Coordinator? Who is acting On Scene Coordinator? Who is acting SMC.?
<b>OTHER SRUs</b>	Other airborne SRUs on scene (call sign, position, task) Ships on scene (call sign, task)
<b>FREQUENCY PLAN</b>	What frequencies are the SRU expected to use and/or monitor? - co ordination with other SAR aircraft - coordination with OSC/ships - hoist frequency? - frequency for transit back after mission.
<b>WEATHER ON SCENE</b>	Flight conditions on scene.



<b>SEARCH MISSION</b>		<b>MASS. EVACUATION</b>	
<b>ROUTEPOINTS</b>	Position of: - Entry point - Exit point	<b>HOIST POSITION</b>	Position of hoist
<b>PATTERN</b>	Search directions Track spacing	<b>ROUTEPOINTS</b>	Position/altitude of: - Reference point - Holding points - Exit point
<b>SEARCH OBJECTS</b>	Primary search object Secondary search object	<b>EVACUATION SITE</b>	Position of evacuation site/post mission landing site.
<b>ADJACENT SRU</b>	Which SRU are operating in close proximity.		
<b>SAFETY ON SCENE</b>	Which safety methods have been implemented.		

## SAR Aircraft Entry and Exit Reports

### Aircraft Entry Report

The Entry Report should be given to ACO/RCC before entering the area of SAR action (at least 20NM/10 minutes flight time to casualty).

1. **Call sign**
2. **Nationality**
3. **Type (specify fixed-wing or helicopter and type)**
4. **Position**
5. **Altitude and altimeter setting**
6. **Estimated Time of Arrival**
7. **Endurance on scene**
8. **Remarks (specific equipment or limitations)**
9. **POB (crew, other personnel)**

Example of Entry Report: "Air Coordinator, Lifeguard 901; one Swedish S-76 rescue helicopter; position 25 NM south of Ronneby; 1500 ft. on QNH 1013; ETA holding point North 1015Z; Endurance on scene 2 hours; no limitations, 4 crew on board"



## Aircraft Exit Report

The Exit Report should be given to the ACO/RCC before leaving the area of SAR action.

1. **CALLSIGN**
2. **Persons on Board (crew, other personnel, rescued)**
3. **Estimated Time of Arrival at destination**
4. **Requirements at destination (fuel, medical care, food etc.)**
5. **Estimated Time of Arrival back in operations area**
6. **Remarks (e.g. Hoist position, weather, etc.)**

Example of Exit Report: " Air Coordinator, Lifeguard 901; total POB 9, 4 crew and 5 rescued; ETA to EVAC 1230Z; Require fuel after landing; ETA back in area 1430Z; hoist position 5535.9N 01659E "

## Pilot Information File

"AIR COORDINATOR" 123.100 MHz	
<b>ENTRY REPORT / 20 NM before reaching area!</b>	
1.	Callsign
2.	Nationality
3.	Type (FIXED/HELICOPTER AND TYPE)
4.	Position
5.	Altitude and altimeter setting
6.	ETA (RELEVANT POINT OR SEARCH AREA)
7.	Endurance on scene
8.	Remarks (EQUIPMENT - LIMITATIONS)
9.	POB (crew, other personnel)
<b>REPORTING</b>	
<ul style="list-style-type: none"> <li>• <b>Reaching</b> assigned points.</li> <li>• <b>Leaving</b> assigned points.</li> <li>• <b>Commencing</b> operations (search, investigation during search, approach to surface/ship, missed approach, hoist, landing etc).</li> <li>• <b>Completing</b> operations, including information regarding results.</li> <li>• Leaving present altitude.</li> <li>• Reaching new altitude.</li> <li>• 10 minutes to completing hoist operation or search.</li> <li>• 30 minutes on scene endurance, expecting fuel at (location)</li> <li>• Exit Report: POB, ETA and requirements at destination, ETA back in operations area and any remarks (hoist position and weather)</li> </ul>	
<b>SEARCH MISSION</b>	
	
<ol style="list-style-type: none"> <li>1. Visual - no restrictions, only traffic reports</li> <li>2. Flow - spacing by flow: separation of ETA, CSP's</li> <li>3. Coordination zones - example 1 NM on each side of border. Call neighbouring helo before entering coordination zone and when exiting 1NM</li> <li>4. No fly zones - Do not enter buffer zone.</li> </ol>	
<p><b>NOTE:</b> The ACO provides only <b>ADVISORY</b> information, aircraft commanders are responsible for the safety of own aircraft. Notify ACO immediately if unable to comply with instructions received.</p>	

## PROPOSED AMENDMENTS TO IAMSAR MANUAL VOLUME III

### 1 Contents

- Add new Section 5 on Multiple Aircraft SAR Operations as follows:

#### Section 5 Multiple aircraft SAR operations

- Add new appendix H as follows:

#### Appendix H

Checklist for multiple aircraft SAR operations	H-1
Example radio communications plan	H-2
ACO Procedure Form – Mass Rescue Operations	H-3
Briefings	H-4
SAR aircraft entry and exit reports	H-5
Pilot information file	H-6

### 2 Abbreviations and Acronyms

- Delete the following text on page vii and page viii

~~GES.....coast earth station~~

~~GES.....ground earth station~~

Add the following text:

RPA Remotely Piloted Aircraft

RPAS Remotely Piloted Aircraft System

SLDMB self-locating datum marker buoy

### 3 Glossary

- Delete the following text on page xiii

~~Coast earth station (CES) Maritime name for an Inmarsat shore-based station linking ship earth stations with terrestrial communications networks.~~

- Amend the Glossary as follows:

---

<b>Cospas-Sarsat System</b>	A satellite system designed to detect and locate activated distress beacons transmitting <del>on</del> in the frequency band of 406.0-406.1 MHz.
<b>Direction Finding (DF)</b>	<del>Homing on signals to pinpoint a position.</del> Radiodetermination using the reception of radio waves for the purpose of determining the direction of a station or object.
<b>Datum marker buoy (DMB)</b>	Droppable floating beacon used to determine actual total water current, or to serve as a location reference. There are two types, the radio type and the self locating datum marker buoy type.
<b>Emergency</b>	<del>Aeronautical distress beacon for alerting and transmitting homing signals.</del> A generic term (related to aircraft) describing equipment which broadcast distinctive signals on designated frequencies and, depending on application, may be automatically activated by impact or be manually activated.
<b>Fetch</b>	The distance the waves have been driven by a wind blowing <del>over which the wind blows</del> in a constant direction, without obstruction.
<b>Maritime Safety Information Service</b>	The internationally and nationally coordinated network of broadcasts containing information which is necessary for safe navigation.
<b>Maritime Safety Information (MSI)</b>	Navigational and meteorological warnings and forecasts and other urgent safety related messages broadcast to ships, as defined in regulation IV/2 of the 1974 SOLAS Convention.
<b>Page NAVAREA</b>	<del>One of 16 areas into which the world's oceans are divided by the International Maritime Organization for dissemination of navigation and meteorological warnings.</del> A geographical sea area established for the purpose of coordinating the broadcast of navigational warnings. The term NAVAREA followed by a roman numeral may be used to identify a particular sea area. The delimitation of such areas is not related to and shall not prejudice the delimitation of any boundaries between States.
<b>Personal locator beacon (PLB)</b>	<del>Personal radio distress beacon for alerting and transmitting homing signals.</del> A portable device, manually activated, which transmits a distress signal on 406 MHz, and may have an additional homing signal on a separate frequency.

**Remotely Piloted Aircraft (RPA)**

an unmanned aircraft which is piloted from a remote pilot station.

**Remotely Piloted Aircraft System (RPAS)**

a remotely piloted aircraft, its associated remote pilot station(s), the required command and control links and any other components as specified in the type design (also known as "un-manned air vehicles (UAV), remotely piloted vehicles (RPV) and un-manned air systems (UAS)".

**Rescue co-ordination centre (RCC)**

Note: The term RCC will be used within this Manual to apply to either aeronautical, maritime or joint centres; ARCC, MRCC or JRCC will be used as the context warrants.

**Rescue sub-centre (RSC)**

... Note: The term RSC will be used within this Manual except where it applies only to aeronautical or maritime; then ARSC or MRSC will be used.

**Self-locating datum marker buoy (SLDMB)**

Droppable floating beacon, equipped with a global navigation satellite system (GNSS) sensor that transmits its location periodically, used to determine actual total water current, or to serve as a location reference.

**Swell direction**

The direction from which a swell is moving. The direction toward which the swell is moving is called the down swell direction.

**Vessel Monitoring System (VMS)**

~~A tracking system which provides for environmental and fisheries regulatory organizations to monitor position, time at a position, course and speed of commercial fishing vessels~~

Systems primarily used by environmental, fisheries and regulatory organizations, but also used by other organizations, to monitor the position, time of the position provided, course and speed of vessels

**4 Section 1**

- Amend page 1-2 last sub bullet as follows:
  - evaluate all reports and modify ~~search~~ action plans as necessary

**5 Section 2, page 2-i**

- Add new subsection at bottom of page after "**Aircraft assisting**"

**Vessel and aircraft actions on observing AIS-SART or AIS MOB device signals**

- Amend page 2-1 first four bullets as follows:
  - A distress call or signal or other emergency information from another vessel at sea, either directly or by relay.
  - A distress call or message from aircraft. This will normally occur by relay from an aircraft, RCC or CRS.
  - ~~Alert from a vessel.~~
  - ~~Visual signals or sound signals from a nearby distressed craft.~~
- Amend page 2-1, second sub-bullet under *Immediate action*, 3 element as follows:
  - Number of ~~POBs~~ persons on board
- Amend page 2-2, first bullet as follows:
  - Vessels should maintain communications with the distressed craft while ~~attempting to advise the SAR system~~ advising an RCC or CRS of the situation.
- Amend page 2-2, fifth bullet as follows:
  - The ship or a CRS coordinating distress traffic should establish contact with ~~the SMC~~ an RCC and pass on all available information, updating as necessary
- Amend text on page 2-5, third bullet as follows:
  - A vessel en route to assist a distressed craft should have the following equipment ready for ~~possible~~ use if possible:
- Add on page 2-5 new 1st bullet under *Life-saving and rescue equipment* as follows:
  - Specialized recovery equipment
- Amend page 2-5 existing 4th bullet under *Life-saving and rescue equipment* as follows:
  - Survival suits ~~for the crew~~
- Amend page 2-6 1st bullet under *Miscellaneous equipment* as follows:
  - ~~If fitted, a gantry~~ A crane for hoisting or other lifting equipment on each ~~either side of the ship,~~ fitted with a cargo net for recovery device of survivors
- Amend page 2-7 second sentence of second bullet under **Aircraft assisting Distress call and message received** as follows:
  - This usually occurs by relay from ~~a CRS~~ an RCC

- Add new subsection on page 2-9 before **Search function**:

#### **Vessel and aircraft actions on observing AIS-SART or AIS MOB device signals**

- Vessels at sea may observe AIS-SART or AIS MOB signals on navigation displays. Although AIS-SARTs and AIS MOB are locating signals, these signals may be related to a vessel or craft that has activated a device to draw attention to its location due to a distress situation and this should be investigated by RCCs. Therefore, AIS-SART and AIS MOB transmissions should not normally be ignored unless information is available that confirms that no response is necessary e.g. it is known to be a false alarm.
  - The majority of vessels will have AIS directly linked to the electronic charting system which means that the SART should automatically be displayed on the navigation display.
  - The AIS-SART and AIS MOB also display on any X band radar as a series of 12 dots for identification.
  - It is recommended that any vessel at sea or aircraft that observes AIS-SART or AIS MOB signals should report this to the nearest RCC immediately. The RCC will then take appropriate actions.
  - Vessels or aircraft should also be prepared to proceed to the location of the AIS-SART or AIS MOB signal, if it is safe to do so, to assist the RCC in investigating the transmission. Because AIS-SART and AIS MOB signals are likely to transmit over relatively short distances e.g. up to 10NM, a vessel should not be significantly delayed by doing this.
- Amend page 2-9 second bullet under *Search action plan and message*, as follows:
    - The OSC and ACO (if designated) and facilities on-scene...
  - Amend page 2-9 first square bullet under *Coordination required* as follows:
    - designates the SMC, ~~and~~ OSC and ACO
  - Amend page 2-9 fourth square bullet under *Coordination required* as follows:
    - OSC and ACO instructions..."
  - Amend page 2-10 third square bullet under *Coordination required* as follows:
    - ...follows coordinating guidance of SMC, ~~or~~ OSC and/or ACO)
  - Amend page 2-10 fourth square bullet under *Communications* as follows:
    - method for OSC and/or ACO to be identified by SAR facilities

- Amend page 2-16 first bullet under **Rescue action plan and message** as follows:
  - ...implementation by the OSC and ACO (if designated) and facilities on-scene..."
- Amend page 2-17 first square bullet under *Coordination* as follows:
  - designates the SMC, and OSC and ACO
- Amend page 2-17 third square bullet under *Coordination* as follows:
  - ...follows coordinating guidance of SMC, or OSC and/or ACO)
- Amend page 2-33 by adding new first bullet under *General maritime considerations* as follows:
  - See also "Recovery of survivors by assisting vessels", below, and the action card "Master's checklist – Recovery of people in the water". The IMO publication Pocket Guide to Recovery Techniques provides additional guidance.
- Amend page 2-33, third bullet under *General maritime considerations* as follows:
  - In heavy weather, an area of sea may be calmed significantly ~~calmed~~ by a large vessel circling at reduced speed
  - oil may also be used for quelling waves: vegetable oils and animal oils, including fish oils, are most suitable for quelling waves..."
- Delete footnote on page 2-35
- Amend page 2-35 by adding new first bullet under *Recovery of survivors by assisting vessels* as follows:
  - Vessels to which Chapter III of the SOLAS Convention applies shall, and other vessels are recommended to, have ship-specific plans and procedures for recovery of people from the water. The action card 'Master's checklist – Recovery of people in the water' and the IMO publication Pocket Guide to Recovery Techniques provide additional guidance.
- Amend page 2-35 by adding new third sub- bullet under *Recovery of survivors by assisting vessels* as follows:
  - utilizing specialized recovery equipment
- Amend page 2-39 sub-bullets under bullet Questions to ask include the following as follows:
  - What was the time and date of the incident?

- What was the last known position?
- What was the total number of persons on board ~~the aircraft~~ prior to the accident?
- ~~What was the total number of persons on board the vessel?~~
- What caused the emergency?
- Were any of the persons able to leave by lifeboat or raft?
- How many survivors did you see in the water?
- What flotation gear ~~had~~ did they have?
- ~~How long was the survivor in the water?~~ If you were in the water, how long for?
- Were search craft seen before the survivors were located and, if so, what were the dates and times of the sightings?
- Were any signals or devices used to try to attract the attention of search craft? If so, what were they and when were they used?

In addition, for aircraft incidents:

- Did you bail out or was the aircraft ditched?
  - If you bailed out, at what altitude?
  - How many others did you see leave the aircraft by parachute?
  - How many ditched with the aircraft?
  - How many did you see leave the aircraft after ditching?
- Amend page 2-52 fifth and sixth sub-bullets under *Radio* by combining them in one sub-bullet as follows:

Merchant ships are ordinarily informed of aircraft distress situations by broadcast messages from a CRS or RCC on the international maritime distress frequencies of 2,182 kHz or 156.8 MHz (VHF channel 16). Few aircraft can operate on these frequencies.

## 6 Section 3

- On page 3-2 delete text of 3rd bullet as follows:
  - ~~LESs may also be referred to as aeronautical ground earth stations (GESs) or maritime coast earth stations (CESs).~~
- Amend page 3-3 first bullet under **OSC duties** as follows:



- Coordinate operations of all SAR facilities on-scene. An ACO may be designated to coordinate aircraft operations
- Amend page 3-3 second bullet under **OSC duties** as follows:
  - Carry out the ~~received~~ search action plan or rescue ~~action~~ plan ~~received~~ from the SMC...
- Amend page 3-3 third bullet under **OSC duties** as follows:
  - Modify the ~~search action or rescue action~~ plan as the situation on-scene dictates, keeping the SMC advised (~~do in consultation~~ discuss proposed modifications with the SMC when practicable).
- Amend page 3-3 second square bullet, eight bullet under **OSC duties** as follows:
  - the results of search and/or rescue action to date
- Amend page 3-3 third square bullet, eight bullet under **OSC duties** as follows:
  - any ~~actions taken~~ modifications made or suggested to the action plan
- Amend page 3-6 first square bullet, eight bullet under bullet Search and rescue... as follows:
  - the OSC may adjust the plans, based on the situation, and inform the SMC (~~do in consultation~~ discuss proposed modifications with the SMC when practicable)
- Amend page 3-7 first bullet as follows:
  - ... should be appointed to assist in maintaining flight safety and to handle communications with the aircraft on scene.
- Amend page 3-8 second square bullet, under first bullet of *Situation reports* as follows:
  - ... an information addressee on all SITREPs from the SMC
- Amend page 3-16 third bullet as follows:
  - On assuming the duty, the OSC should inform the appropriate RCC, via a CRS or ATS unit as necessary, and keep it informed of developments at regular intervals.
- Delete page 3-16 fourth bullet
- Amend page 3-35 first bullet, under **SAR briefing, debriefing and tasking** as follows:
  - The SMC, ~~or OSC~~ and/or ACO should provide information to SAR facilities..."
- Amend page 3-36 first bullet, as follows:

- ...units should also be contacted by the SMC, or OSC and or ACO for debriefing
- Amend page 3-36 first and second bullets, under **Further action on ...** as follows:
  - The ~~OSC will normally consider the~~ initial phase is normally considered to have been completed when, in the absence of further information, searching ships have completed one search of the most probable area.
  - If at that stage nothing has been located, it will be necessary for the SMC, in consultation with the OSC, to consider the most effective method of continuing the search."
- Amend page 3-37 third bullet as follows:
  - The SMC and OSC should, therefore, consider using surface craft at night to ~~research~~ search again areas covered by day."
- Amend page 3-41 second bullet, under **Search unsuccessful** as follows:
  - The OSC may need to decide whether to terminate an unsuccessful search. ~~(do in consultation with the SMC when practicable)~~ This should be discussed with an RCC whenever practicable. For this determination...
- Amend page 3-42 text under the first bullet:

#### ~~Ocean incident~~

- terminate active search and inform the RCC
- advise assisting craft to proceed on passage and inform the land-based authority
- send a message to all ships in the area asking them to continue to keep a look-out

#### ~~Coastal incident~~

~~Consult with land-based authorities about the termination of search~~

- Amend page 3-42, fourth bullet under **Search successful** as follows:
  - When all ~~rescuing action has been effected~~ persons in distress have been accounted for, the OSC should immediately inform all search facilities that the search has been terminated.

## 7 Section 4

- Amend page 4-i as follows:

Add new subsection called "Guidance for Vessels" after section Evacuation by helicopter

- Amend page 4-4 as follows:

### **EPIRBs, ELTs and personal locator beacons (PLBs) distress beacons**

- Some ELTs and EPIRBs may also have integral GPS capabilities.

- ~~• It is recommended that an activated distress beacon, even if inadvertently activated (false alarm), be kept on until the RCC is informed.~~
- ~~▪ this enables the RCC to work with a more accurate position and identification, allowing resolution of the alert without dispatching SAR facilities needlessly~~
- ~~▪ immediately attempt to notify the RCC by other means that the alert is false.~~
- The followings steps should be followed when a distress beacon is inadvertently activated:
  - Switch the distress beacon OFF; and
  - immediately attempt to notify the RCC that the alert is false.

In cases were the beacon cannot be turned OFF, take measures to prevent or inhibit transmission of signal (e.g. shielding of transmission, battery removal, etc.) Such actions may prevent future use of the distress beacon.

**Note:** There is no penalty for inadvertent activation of a distress beacon.

- Amend page 4-10 as follows:

Add new subsection called "Guidance for Surface Vessels" after section Evacuation by helicopter

### **Guidance for Vessels**

#### *SRUs*

Vessels taking part in a SAR mission in the vicinity of aircraft operations, should consider the following:

- keep clear of aircraft approach path (area between Final Point and distress vessel)
- keep clear of missed approach flight path
- inform ACO/OSC/SMC of any activity observed in above-mentioned areas
- ask ACO for guidance concerning the placement of the areas mentioned above in case they are unclear
- the ACO/OSC/SMC may also ask a surface SRU to remain in certain position relative to a distressed vessel to accommodate operational needs, for example act as an approach fix for aircraft airborne radar approaches
- in search missions including both airborne and surface units, keep the ACO/OSC/SMC aware of own position as advised

#### *Distress vessel*

In addition to other guidance given to vessels, in multiple aircraft SAR operations or mass evacuation situations, the Master of the vessel in distress should consider the following:

- agree on cooperation with airborne units with ACO/OSC/SMC including:
  - determine landing/hoist positions
  - determine working channels
  - inform when ready to receive helicopters
  - be prepared to provide ship manifest to RCC or SRU
  - be prepared to guide rescue personnel arriving on ship
  - be prepared to gather passengers to landing/hoist positions and to guide them
  - determine medical triage status and number of casualties
  - plan order of evacuation and relay to RCC/OSC/ACO
  - update vessel position, speed and course at regular intervals; 1NM can be considered a significant difference in position for aircraft especially in poor weather conditions
  
- Amend page 4-14 11th bullet under Initial actions as follows:
  - Prepare lifeboat for possible launching recovery equipment – see Section 2, Recovery of survivors by assisting vessels
  
- Delete page 4-14 last bullet under Initial action
  - ~~Rig pilot ladder to assist in recovery~~
  
- Amend page 4-14 title of last section as follows:

### **Standard methods of recovery manoeuvres**

- Delete page 4-17, fourth square bullet under *Collision*
  - ~~POB control (vessels involved)~~

## **8 Section 5**

- Add new Section on Multiple Aircraft SAR Operations as follows:

### **Section 5**

Multiple aircraft SAR operations

---

#### **Contents**

General guidance .....	Page X
Area of SAR action .....	Page X
Aircraft coordinator ....	Page X
Communications .....	Page X
Search missions.....	Page X
Evacuation missions .....	Page X
Long range operations ..	Page X

## **General guidance**

The information in this section provides guidance for the management and conduct of multiple aircraft SAR operations. Any of the described principles and procedures might have to be modified by SMCs, ACOs and SRUs, in order to deal with specific situations. Further information on multiple aircraft SAR operations is available in IAMSAR Volume II, chapter 6.

## **Number of SAR Aircraft Required and Aircraft Capabilities**

The RCC/OSC/ACO responsible for the SAR operation should aim to achieve the most effective blend of aircraft and surface unit capabilities for the situations that are anticipated. The operation should aim to achieve continuous or efficient use of aircraft on scene when needed, while minimising the situations in which aircraft are airborne without a mission. Where more aircraft than needed are available for a SAR operation, some can be held in reserve. These aircraft can provide additional resources if needed, or relieve other aircraft involved in the operation for reasons related to aircrew fatigue or maintenance requirements.

The RCC/OSC/ACO should define the number of aircraft to be used in a mission taking into account weather, distance from scene, nature of distress, available facilities and other operational issues. The SMC ideally has the best overall picture of ongoing SAR operations. Therefore tasks given to aircraft may not necessarily always utilise all the capabilities available.

Given tasks should not rely on aircraft and aircrew conducting flying activities beyond their abilities, or their approved types of operations. In case such a task is given, the pilot-in-command shall inform the RCC/OSC/ACO immediately.

## **Participation by Other Aircraft**

In some situations, such as mass evacuations from offshore drilling platforms, large scale incidents over land areas etc., aircraft belonging to commercial companies or other organizations might be able to respond to incidents as part of existing emergency plans.

## **Refuelling Facilities**

The RCC/ACO/OSC is responsible for arranging refuelling facilities in a SAR operation. The pilot-in-command is responsible for ensuring that the facilities available are suitable, taking into account endurance and all operational needs. The pilot-in-command should take appropriate actions to ensure required refuelling and keep the RCC/ACO/OSC continuously informed of changes to on-scene and overall endurance.

## **Area of SAR action**

### **Definition**

For IAMSAR Manual purposes, an area of SAR action is an area of defined dimensions that is established, notified or agreed for the purposes of protecting aircraft during SAR operations and within which SAR operations take place.

### **Entering Areas of SAR Action**

SAR aircraft intending to enter an area of SAR action should normally first contact the ACO. They should not enter the area until the ACO gives them permission and provides them with sufficient information to safely join the flow of SAR aircraft involved in the operation (see also Communications). Aircraft should call an ACO as early as possible before entering an area of

SAR action, in order to allow time for information to be exchanged and in case they are required to remain clear of it. As a general guide, aircraft should aim to get in touch with an ACO when at least ten minutes' flying time from the edge of an area of SAR action and pass entry information using the format described in appendix H - 5. In the event that an area of SAR action has been established but an ACO is not yet available, SAR aircraft should receive information that they require from the coordinating RCC.

### **Leaving Areas of SAR Action**

Aircraft leaving areas of SAR action should contact the ACO before the area boundary and before changing to another frequency. Aircraft leaving should use the format described in appendix H - 5.

### **Flights in Areas of SAR Action by Other Aircraft**

Aircraft that are not involved in a SAR operation should normally not fly within areas of SAR action. However, if such aircraft need to enter an area of SAR action, they should do so only with the approval of a SMC, ACO or coordinating ATS unit and are subject to the rules of the area or the relevant class of airspace. If a SMC or coordinating ATS unit is giving approval, the ACO should first be consulted.

### **Aircraft coordinator**

#### **Purpose of an ACO**

The primary purpose of an ACO is to contribute to flight safety of aircraft involved in a SAR operation. The ACO should have a clear understanding of the aim of a SAR operation. The ACO organizes and coordinates the operations of aircraft involved in the SAR mission to carry out the mission effectively, paying particular attention to aircraft that are likely to operate close to each other.

#### **Responsibility for Safety**

Information from ACOs to other aircraft on scene is advisory, but should nevertheless be followed as closely as practicable. If necessary to ensure flight safety, aircraft pilots-in-command should take whatever measures they assess are needed. If aircraft pilots-in-command deviate from advice passed by an ACO, then they should inform the ACO as soon as possible. The final decision concerning the safety of an aircraft, its crew and passengers rests with the pilots-in-command of the aircraft involved.

#### **ACO Duties**

Procedures, duties and tasks involving ACOs are described throughout this Section. A list of normal duties for an ACO, also contained in IAMSAR Volume II, can include the following tasks:

(a) Contributing to flight safety:

- maintain a safe flow of aircraft
- ensure use of a common altimeter setting for all aircraft involved
- advise the SMC of on-scene weather implications
- determine a direction for entering and leaving an area of SAR action
- determine all points necessary for maintaining safe flow in an area of SAR action
- filter radio messages to and from SAR aircraft

- ensure frequencies are used in accordance with SMC directives
- coordinate with adjacent air traffic services (ATS) units

(b) Prioritizing and allocating tasks:

- ensure SAR aircraft are aware of the SMC/OSC overall plan and their own tasks
- monitor and report search area coverage
- with appropriate SMC/OSC, identify emerging tasks and direct SAR aircraft to meet them.

(c) Coordinating aircraft operations:

- respond to changing factors on scene and supervise effectiveness of operations
- ensure the continuity of aircraft operations in coordination with SMC/OSC

(d) Informing SAR aircraft:

- Assign tasks to aircraft.
- Distribute all relevant flight safety information to aircraft (ref sub paragraph (a) above)
- Provide information about relevant air activity and dangers on scene.
- Provide information about search areas (if applicable) evacuation points (if applicable) and refuelling facilities.
- Provide operational information about the ongoing SAR-mission
- Provide relevant weather information.

(e) Make periodic situation reports (SITREPs) of SAR aircraft operations to the SMC and the OSC, as appropriate.

(f) Work closely with the OSC:

- assist in the execution of SMC directives
- maintain communications
- advise on how the ACO can assist.

(g) Coordinate aircraft refuelling.

### **ACO Location**

The ACO function may be carried out from various locations, such as a fixed-wing aircraft, a helicopter, a ship, a fixed structure such as an oil rig, an ATS unit, a coordinating RCC or another appropriate land unit. The procedures used should be similar regardless of the ACO location.

### **Information from SAR Aircraft to the ACO**

In order to enhance situational awareness for ACOs and other SAR aircraft and to assist with safety and the continuity of operations, participating aircraft should report as follows:

- Entry report.
- Reaching assigned points.

- Leaving assigned points.
- Commencing operations (search, investigation during search, approach to the surface/ship, missed approach, hoist, landing, etc.).
- Completing operations, including information regarding results.
- Leaving present altitude.
- Reaching new altitude.
- 30 minutes on scene endurance, expecting fuel at (location).
- 10 minutes to completing hoist operation.
- 10 minutes to completing search
- Exit report

### **Transfer of ACO tasks**

Before accepting the task the new ACO should understand the details of the SAR mission and the SMC's plans. The details required include the aim of the operation, the position of the missing object, number of persons in distress, other units involved, locations of participating aircraft, communications and any limitations to the operation. When possible, basic pre-flight information should be provided by a SMC in order to simplify the transfer to the new ACO.

### **Checklists and Guides**

ACOs and SAR aircraft are recommended to use checklists or guides containing relevant information. Units who are likely to be designated as ACOs or take part as airborne SRUs in the event of a multiple aircraft SAR operation, should always have ACO checklists or guides available whenever they are on duty.

A short reference list known as the 'Pilot Information File' (PIF) contains information useful for all aircraft involved in multiple aircraft operations. The PIF, guides and checklists suitable for ACOs and SAR aircraft are contained in appendix H - 6.

### **Communications**

#### **ACO Call sign**

Multiple aircraft SAR operations can involve units from different organizations or SRRs, which might not routinely work together. In order to make the identity of an ACO clear to all participating units, the standard call sign: 'Air Coordinator' should be used by all ACOs.

#### **Radio Voice Communications**

There should be agreed, common, on scene procedures for the following:

- (a) On Scene Coordination Frequency. An agreed coordination frequency for radio voice communications should be used within an area of SAR action or near the scene of operations. This frequency should be one that all aircraft can access, together with the ACO. Information that should be passed between an ACO and SAR aircraft are listed in appendices H-3, H-4 and H-5.
- (b) Alternative Frequencies. Alternative frequencies should also be nominated by an ACO, if the agreed coordination frequency is likely to become too busy or unusable.



- (c) Capabilities. Care should be taken to ensure that aircraft and surface units involved in an operation are capable of complying with the communications procedures.
- (d) Communications with an OSC. Consideration should be given to enabling communications between an ACO and an OSC. However, it should not normally be necessary for SAR aircraft other than an ACO to communicate directly with the OSC.
- (e) Radio Communications Failure Procedures. All SAR plans for multiple aircraft SAR operations should include procedures for use when radio communications fail. A failure of radio communications might affect aircraft, SRUs or persons in distress individually, or might involve a compromise of radio systems affecting several participants. The systems affected might include radio voice communications or radio systems designed to indicate the positions of aircraft, vessels or people, including transponders and other devices. In general, the following principles should apply to most situations in which radio communications fail:
- A backup means of radio voice communication should be determined and then nominated by an ACO, along with the normal communications plan.
  - The backup radio voice communications might include alternative frequencies, alternative radio communications systems or both. In the event of a radio communications failure, with no alternative airborne communications available, aircraft should normally continue with their planned timings, events and flight path, still transmitting all position and altitude reports, until they are clear of the immediate on scene area.
  - If an aircraft has not been given a plan when a radio communications failure occurs, then it should avoid the on scene area, departing by an appropriate route and heights.
  - Once clear of the on scene area, aircraft should consider moving near or landing at a suitable facility in order to establish communications by alternative methods.

If radio voice communications cannot be restored, then alternative procedures could be considered such as increasing the distances between aircraft using time. If not already included in SAR plans, then all participating airborne SRUs might have to be assembled together in order for this procedure to be briefed and understood. In most cases, this would result in considerable delays to a SAR operation.

A diagram illustrating a basic example of communications during multiple aircraft SAR operations, involving an aircraft ACO is as follows:

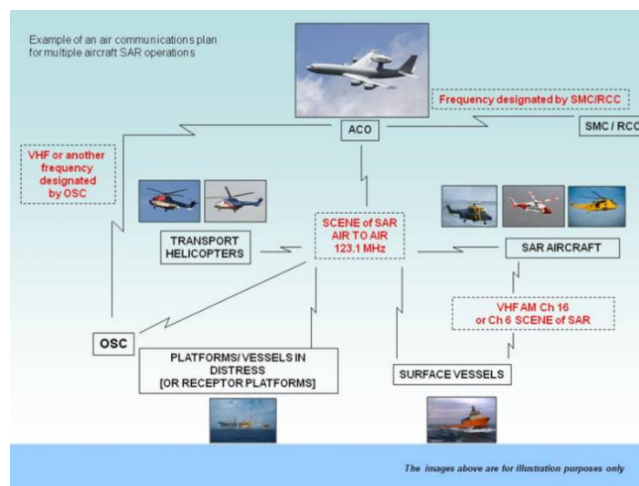

## Long Range Radio Communications

Communications systems designed for long range SAR operations can be different from the types of communications used at shorter ranges.

Some long range communications methods include the following:

- (a) High Frequency radio systems.
- (b) Satellite communications systems.
- (c) Position tracking systems, including those that enable two-way communications.
- (d) The use of high flying aircraft to relay VHF radio communications to and from lower flying SAR aircraft.
- (e) Relay of information to and from SAR aircraft through ATS units.
- (f) Relay of information by ships at sea able to communicate with SAR aircraft on marine band VHF frequencies, whilst a shore based RCC uses satellite, MF or HF communications to communicate with the relaying ship(s).
- (g) Relay of information by any surface units able to communicate with both SRUs and SMCs.

## Search missions

### General

Factors relevant to search operations are described in IAMSAR Volume II, chapters 4 and 5.

The most likely situations in which multiple aircraft might be involved in searches is when large areas need to be searched in which the confidence of the datum position is low

The procedures described below generally assume that visual search techniques are used. However, other techniques such as radar or FLIR searches might also be required or SAR aircraft might only be able to locate persons in distress by homing onto transmissions from emergency distress beacons, transponders or other devices. In these situations, techniques might have to be modified and the need for multiple SAR aircraft might have to be considered carefully.

## Safety and Search Effectiveness

ACO and SAR aircraft should use procedures that ensure flight safety, without making the search ineffective. Aircraft should be given sufficient operational freedom to carry out their searches effectively, but should conform to safety procedures briefed by the ACO. The ACO should encourage a high degree of situational awareness amongst the aircraft.

Methods used to safely keep aircraft apart will depend on the on scene conditions. Beginning with good weather conditions and progressing to poor conditions, methods for keeping aircraft apart can be as follows:

- (a) Visual Methods.
- (b) Flow Methods.
- (c) Coordination Zones.
- (d) No Fly Zones.

### Visual Methods

Visual methods involve the ACO allocating aircraft to search areas and aircraft avoiding each other visually. Visual methods may be the only measure necessary when weather conditions on scene are good. When using visual methods, the ACO can allow aircraft more freedom of action compared to other, more restrictive, methods. However, this freedom will not relieve the aircraft or ACOs from other duties outlined earlier in this section, for example providing information on air activity or making aircraft reports.

### Flow Methods

Flow methods can be used to keep SAR aircraft apart in slightly poorer conditions, by ensuring that they fly the same search patterns (commence search point /line of advance, etc.) but in adjacent search areas. The first aircraft on scene should be allocated the search area furthest away from the LOA. This method enables aircraft to execute effective searches of areas with a minimum of radio communication.

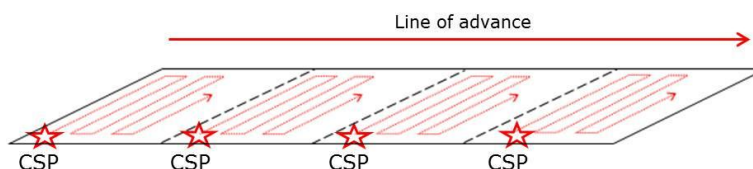

The ACO may order specific search altitudes for SRUs, to allow an extra margin of safety when aircraft operate in close proximity to each other. However, in this situation the ACO should be aware that any limit to the operational freedom of an aircraft, particularly in altitude, could reduce the effectiveness of the search. The ACO should also expect aircraft to deviate from their assigned altitudes if they need to investigate objects on the surface. **ACOs should ensure that all aircraft use the same reference for altitude.**

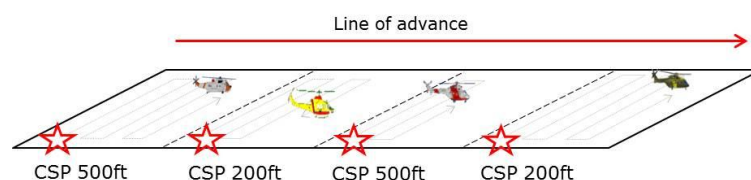

## Coordination Zones

Coordination zones are border areas established by an ACO between adjacent search areas, which SAR aircraft can only enter under specific conditions. Coordination zones enable aircraft to have operational flexibility within their allocated search areas and ensure a level of safety between them.

The dimensions of a coordination zone depend on the on-scene conditions and the size of a search area. As a general guide a coordination zone might be 2 nautical miles across, but this size may be increased or decreased if needed. Before entering a coordination zone, aircraft sharing the zone should communicate with each in order to safely coordinate the entry. The aircraft should call again when leaving the zone. The ACO should ensure that the aircraft have a clear understanding of their mutual operating areas.

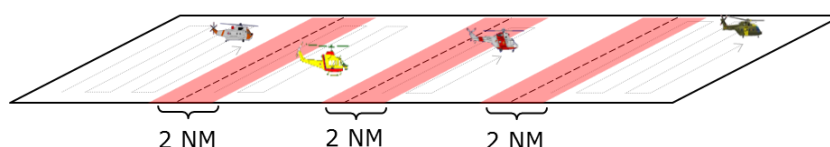

## No Fly Zones

If on scene conditions are sufficiently difficult, no fly zones can be used in which flight is not permitted while searching is taking place in adjacent areas. The dimensions of no fly zones can be similar to coordination zones. Whenever no fly zones are used, the ACO should coordinate with the SMC and OSC to ensure that the zones are searched appropriately during the SAR mission.

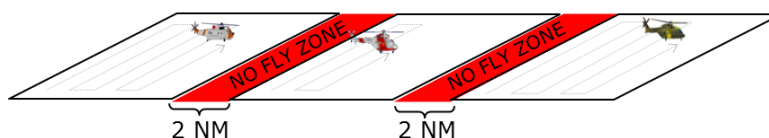

## Evacuation missions

### Safety Flow Procedures

The main aim of on scene procedures for multiple aircraft operations should be safety. In general, there are two methods that can be used to ensure a safe flow of SAR aircraft, which are as follows:

- (a) Horizontal Spacing. Horizontal spacing of aircraft should be the basic method used by SAR authorities and ACOs. It can be achieved by establishing specific routes to be flown by SAR aircraft to, from and within the area of SAR action.
- (b) Vertical Spacing. For situations in which keeping aircraft apart horizontally will not ensure sufficient levels of safety, or if a cross-over of aircraft flight paths cannot be avoided then, when weather permits, vertical spacing should be considered. It may not always be necessary for SAR aircraft to fly at different altitudes, unless they are likely to fly close to each other or their flight paths cross over. If a significant possibility of collision exists, then different altitudes should be assigned for SAR aircraft.

- (c) In general, altitudes for RPAs should be kept apart from altitudes allocated for other SAR aircraft.  
Ideally, the most effective method to ensure a safe flow of aircraft is by using a combination of both horizontal and vertical spacing. The best way to achieve this is through planning by an ACO and a clear understanding of procedures by all of the units and authorities involved.

### **Aircraft Approach and Departure Flight Paths**

Approach and departure flight paths are usually influenced by the prevailing wind direction; factors which might also have to be taken into account are:

- (a) Fumes directly downwind from burning structures may be unsafe – the direction of approach for aircraft might have to be off-set from the wind direction.
- (b) Geographic features or the design of the casualty location might compel aircraft to approach only from certain directions. Structures such as cranes, towers or vertical obstructions in line with the wind direction, might be dangerous.

### **Long range operations**

#### **General**

Long range is any distance that significantly limits or compromises the ability of SAR aircraft to operate on scene effectively and safely.

#### **Long range procedures**

At long ranges, SAR aircraft might need to minimize the fuel used while flying in transit, in order to permit more time operating on scene. It might be necessary for SAR aircraft to fly as directly as possible to and from an incident, with the result that multiple aircraft SAR procedures have to be modified and rely on basic safety arrangements. These arrangements could include separate arrival times on scene and basic inbound and outbound height differences in order to keep aircraft safely apart. Additional considerations for long range SAR communications are described earlier in this Section.

### **Bringing a Casualty Vessel Within Range**

If the casualty is a vessel underway, SMCs should consider the possibility of directing it to move to a point within the effective range of SAR aircraft or other forms of assistance. Alternatively, it might be possible for SAR aircraft to refuel at locations that effectively bring a casualty within their maximum radius for SAR operations. It is also effective for SMCs to use both of these options at the same time.

---

#### Appendix H:

- H-1 Checklist for Multiple Aircraft SAR Operations
- H-2 Example Radio Communications Plan
- H-3 ACO Procedure Form - Mass Rescue Operations
- H-4 Briefings
- H-5 SAR Aircraft Entry and Exit Reports
- H-6 Pilot Information File

## 9 Action Card

- Add new action card as follows:

### Masters checklist

#### RECOVERY OF PEOPLE IN THE WATER

Additional information may be found in MSC.1/Circ.1182/Rev.1 GUIDE TO RECOVERY TECHNIQUES, the IMO's *Pocket Guide to Recovery Techniques*, and in IAMSAR Manual Volume III, section 2. .

##### ON PASSAGE TO THE INCIDENT

- Establish communications with the Rescue Coordination Centre (RCC)
- Establish communications with the On Scene Coordinator (OSC), if appointed
- Re-read the ship-specific recovery plan
- Read IMO's recovery guidance: the *Pocket Guide* or the MSC Circular (see above) and the relevant sections of the IAMSAR Manual
- Check the IMO's guidance on cold water survival: the *Pocket Guide to Cold Water Survival* or MSC Circular 1185 (MSC.1/Circ.1185/Rev.1)
- Consider on-scene conditions
- Consider the number and type of people you may have to recover, and the condition they may be in: they may be injured and/or incapable
- Consider whether to launch rescue craft
- Assess the best points of entry into the ship with the prevailing conditions in mind
- Advise RCC and/or OSC of your expected recovery capability
- Brief crew, and any passengers aboard
- Prepare recovery equipment, including control and safety measures
- Prepare additional life-saving equipment in case of accidents during recovery
- Prepare reception facilities for those recovered
- Prepare to provide assistance prior to, or instead of, recovery

Continue other side.....

- Assign crew to
  - handling the ship
  - lookout duties
  - recovery
  - care of survivors – passengers may be able to assist with this
- People who have been in the water should be lifted in a horizontal or near-horizontal position if possible
- A crew member wearing personal protective equipment may be able to go down with the lift to assist those incapable of helping themselves

##### APPROACHING THE SCENE

- Post lookouts, well-briefed and in communication with the Bridge
- Have recovery team(s) standing by, well-briefed, equipped with personal protective equipment, and in communication with the Bridge
- Assess your ship's manoeuvrability and recovery capability in the prevailing conditions
- Prepare to launch rescue craft, if conditions permit
- Prepare to receive craft and/or people alongside
- Think about your best approach
- Determine the priorities
- Advise RCC and/or OSC of your arrival and capabilities

##### DURING THE RECOVERY OPERATION

- Continue to assess the priorities
- Continue your risk assessment, including your own ongoing recovery capability, the survival chances of those not yet recovered, and the availability of other recovery resources
- Keep RCC and/or OSC advised of your progress and future capability

10 **Appendix H**

- Add Appendix H as follows:

**Appendix H-1 Multiple Aircraft SAR Operations**

**Checklist for Multiple Aircraft SAR Operations**

The Checklist below is for example purposes and for general guidance only. Each SAR operation is different therefore not all of the items below might be needed and additional ones might be required. Some items might also be carried out by different facilities and units from those indicated below.

SERIAL	TASK	ACO	SMC	ATS	SRU
1	Declare Emergency Phase		X		
2	Identify Requirement for ACO		X		X
3	Designate and Notify ACO	X	X		
4	Inform ATS units & Establish Area of SAR Action		X	X	
5	Identify Aircraft And Capabilities	X	X		
6	Develop and Promulgate Plan	X	X		X
7	Establish Co-operation with OSC	X	X		
8	Co-ordination with ATS	X	X	X	X
9	Manage Aircraft Activities	X	X	X	
10	Call ACO before Entering Area	X			X
11	Call ACO when leaving Area	X			X
12	Monitor and Update On Scene Plan	X	X		
13	Provide Regular Situation Reports	X	X		
14	Manage Fuel & Numbers of airborne SRUs	X	X	X	X
15	Stand Down or Relieve the ACO	X	X		
16	Cancel/ Terminate the SAR Operation	X	X	X	X
17	Cancel Area of SAR Action	X	X	X	X

Notes:

1. 'X' signifies action required or the receipt of information
2. For the purposes of this checklist, 'SRU' refers to aircraft involved in the SAR operation.

**Appendix H - 2 Multiple Aircraft SAR Operations**

**Example Radio Communications Plan**

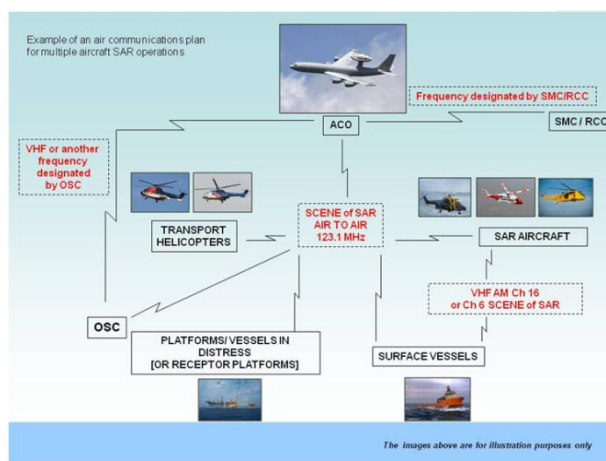

**Appendix H - 3 Multiple Aircraft SAR Operations**

**ACO Procedure Form-Mass Rescue Operations**

GENERAL INFORMATION	
OPERATION	
EMERGENCY LOCATION	
IDENTIFICATION (VERSION)	
TIME ZONE	
ACO INFORMATION	
ACO FREQUENCY	
ACO TEL / EMAIL	
WAYPOINTS	
REFERENCE POINT	
EXIT POINT	
HOLDING POINT	
HOLDING POINT	
HOLDING POINT	
EVACUATION SITE	
EVACUATION SITE	
REFUELING/CREW SUPPORT	
ALTITUDES	
ENROUTE/ENTRY	
HOLDING POINT(S)	
EXIT POINT	
ENROUTE/LEAVING AREA	
NATURE OF DISTRESS AND/OR SEARCH OBJECTS	
SAFETY BRIEF	
<p><i>"The Air Coordinator will only provide advisory information. You (the Aircraft Commander) are responsible for the safety of your own aircraft at all times. If you, because of safety reasons, are unable to comply with instructions given by ACO, you are to notify me (ACO) immediately."</i></p>	
PICTURE OF ACO PROCEDURE	
MISSED APPROACH PROCEDURE	
OPERATIONAL INFORMATION	
COMM PLAN	WEATHER ON SCENE + QNH
ACO 123,100 RCC/OSC CH SHIPS CH OTHER	WIND VIS CLDS TEMP QNH



**Appendix H-4 Multiple Aircraft SAR Operations**

**Briefings**

The ACO should ensure that the following information is briefed to the SAR aircraft after check in and when appropriate

<b>SAFETY BRIEF</b>	"The Air Coordinator will <u>only</u> provide advisory information. You are responsible for the safety of you own aircraft at all times. If you because of safety reasons are unable to comply with instructions given by the Air Coordinator , you are to notify me immediately"
<b>QNH/ALT.</b>	Which reference is used for common altimeter setting?
<b>ORGANISATION ON SCENE</b>	Who is acting Aircraft Coordinator? Who is acting On Scene Coordinator? Who is acting SMC.?
<b>OTHER SRUs</b>	Other airborne SRUs on scene (call sign, position, task) Ships on scene (call sign, task)
<b>FREQUENCY PLAN</b>	What frequencies are the SRU expected to use and/or monitor? - co ordination with other SAR aircraft - coordination with OSC/ships - hoist frequency? - frequency for transit back after mission.
<b>WEATHER ON SCENE</b>	Flight conditions on scene.



<b>SEARCH MISSION</b>		<b>MASS. EVACUATION</b>	
<b>ROUTEPOINTS</b>	Position of: - Entry point - Exit point	<b>HOIST POSITION</b>	Position of hoist
<b>PATTERN</b>	Search directions Track spacing	<b>ROUTEPOINTS</b>	Position/altitude of: - Reference point - Holding points - Exit point
<b>SEARCH OBJECTS</b>	Primary search object Secondary search object	<b>EVACUATION SITE</b>	Position of evacuation site/post mission landing site.
<b>ADJACENT SRU</b>	Which SRU are operating in close proximity.		
<b>SAFETY ON SCENE</b>	Which safety methods have been implemented.		

**Appendix H - 5 Multiple Aircraft SAR Operations**

**SAR Aircraft Entry and Exit Reports**

**Aircraft Entry Report**

The Entry Report should be given to ACO/RCC before entering the area of SAR action (at least 20NM/10 minutes flight time to casualty).

1. Call sign
2. Nationality
3. Type (specify fixed-wing or helicopter and type)
4. Position
5. Altitude and altimeter setting
6. Estimated Time of Arrival
7. Endurance on scene
8. Remarks (specific equipment or limitations)
9. POB (crew, other personnel)

Example of Entry Report: "Air Coordinator, Lifeguard 901; one Swedish S-76 rescue helicopter; position 25 NM south of Ronneby; 1500 ft. on QNH 1013; ETA holding point North 1015Z; Endurance on scene 2 hours; no limitations, 4 crew on board"

### Aircraft Exit Report

The Exit Report should be given to the ACO/RCC before leaving the area of SAR action.

1. **CALL SIGN**
2. **Persons on Board (crew, other personnel, rescued)**
3. **Estimated Time of Arrival at destination**
4. **Requirements at destination (fuel, medical care, food etc.)**
5. **Estimated Time of Arrival back in operations area**
6. **Remarks (e.g. Hoist position, weather, etc.)**

Example of Exit Report: "Air Coordinator, Lifeguard 901; total POB 9, 4 crew and 5 rescued; ETA to EVAC 1230Z; Require fuel after landing; ETA back in area 1430Z; hoist position 5535.9N 01659E"

## Appendix H - 6 Multiple Aircraft SAR Operations

### Pilot Information File

<b>"AIR COORDINATOR" 123.100 MHz</b>	
<b>ENTRY REPORT / 20 NM before reaching area!</b>	
1.	Callsign
2.	Nationality
3.	Type (FIXED/HELICOPTER AND TYPE)
4.	Position
5.	Altitude and altimeter setting
6.	ETA (RELEVANT POINT OR SEARCH AREA)
7.	Endurance on scene
8.	Remarks (EQUIPMENT – LIMITATIONS)
9.	POB (crew, other personnel)
<b>REPORTING</b>	
<ul style="list-style-type: none"><li>• <b>Reaching</b> assigned points.</li><li>• <b>Leaving</b> assigned points.</li><li>• <b>Commencing</b> operations (search, investigation during search, approach to surface/ship, missed approach, hoist, landing etc).</li><li>• <b>Completing</b> operations, including information regarding results.</li><li>• Leaving present altitude.</li><li>• Reaching new altitude.</li><li>• 10 minutes to completing hoist operation or search.</li><li>• 30 minutes on scene endurance, expecting fuel at (location)</li><li>• Exit Report: POB, ETA and requirements at destination, ETA back in operations area and any remarks (hoist position and weather)</li></ul>	
<b>SEARCH MISSION</b>	
	
<ol style="list-style-type: none"><li>1. Visual – no restrictions, only traffic reports</li><li>2. Flow – spacing by flow: separation of ETA, CSP's</li><li>3. Coordination zones – example 1 NM on each side of border. Call neighbouring helo before entering coordination zone and when exiting 1NM</li><li>4. No fly zones – Do not enter buffer zone.</li></ol>	
<b>NOTE:</b> The ACO provides only <b>ADVISORY</b> information, aircraft commanders are responsible for the safety of own aircraft. Notify ACO immediately if unable to comply with instructions received.	